

**MINUTES
SELMA CITY COUNCIL
SPECIAL MEETING**

**February 7, 2022
5:00 PM**

Selma City Council Chambers
1710 Tucker Street
Selma, CA 93662

Call to order: Mayor Robertson called the Special Meeting to order at **5:00 p.m.**

Roll Call: Present - Council members Guerra, Mendoza-Navarro, Trujillo, Mayor Pro Tem Cho, and Mayor Robertson

Potential Conflicts of Interest: Any Council member who has a potential conflict of interest may now identify the item and recuse themselves from discussing and voting on the matter.

There was no Conflict of Interest declared.

ORAL COMMUNICATIONS

NOTICE(S) TO THE PUBLIC: At this time, any member of the public may address the City Council regarding any item on the special meeting agenda over which the Council has jurisdiction. No action or discussion will be taken on any item not on the agenda. Issues raised will be referred to the City Manager for review. Members of the public shall limit their remarks to three (3) minutes.

Mayor Robertson asked for public comments, seeing none, he closed the public comments.

WORKSHOP

SELMA KINGSBURG FOWLER (SKF) COUNTY SANITATION DISTRICT AND CITY OF SELMA SEWER INFRASTRUCTURE NEEDS DISCUSSION

Selma Kingsburg Fowler County Sanitation District (SKF) General Manager Ben Munoz, and Engineer Veronica Cazares provided an overview of the services that SKF provided to the City.

Council member Guerra announced she sits on the Board of SKF for the City of Selma.

City Manager Santillan reported that City and SKF staff have met on occasions to discuss projects and plans for the budget and would like to meet with them again for an overview of those projects.

Council requested SKF provide project plans, maintenance scheduled routine schedules, Timelines and goals of SKF, and any upgrade scheduled for Selma that they may have.

At this point in the meeting, there was much discussion regarding City growth, communication, continued maintenance and project timelines.

Mayor Robertson asked for public comments, the following citizens spoke: Mr. Louis Franco and Mr. Baldev Josan.

ADJOURNMENT: There being no other business, Mayor Robertson adjourned the meeting at 6:03 p.m.

Respectfully submitted,

Reyna Rivera, City Clerk

**MINUTES
SELMA CITY COUNCIL
REGULAR MEETING**

February 7, 2022

Selma City Council Chambers

1710 Tucker Street
Selma, CA 93662

PURSUANT TO EXECUTIVE ORDER N-29-20 ISSUED BY GOVERNOR GAVIN NEWSOM, THE PUBLIC HAD THE OPTION TO CALL +1 301 715 8592 ID: 849 1774 7638 TO PROVIDE COMMENTS ON AGENDA ITEMS. THE COUNCIL CHAMBER WAS OPEN FOR THE PUBLIC AS WELL.

The regular meeting of the Selma City Council was called to order at 6:07 p.m. in the Council Chambers and by teleconference. Council members answering roll call were: Guerra, Mendoza-Navarro, Trujillo, Mayor Pro Tem Cho, and Mayor Robertson.

INVOCATION: Chaplain Bucky Weeks of Adventist Medical Center-Selma led the invocation. Mayor Robertson asked for a moment of silence in honor of Alfred Mares.

Pledge of Allegiance was led by Council Member Mendoza-Navarro.

ORAL COMMUNICATIONS: Public comment was received from Mr. Jose Ramirez.

SWEARING IN CEREMONY- CITY MANAGER FERNANDO SANTILLAN

City Manager Fernando Santillan took the Oath of Office from City Clerk Rivera. City Manager Santillan introduced his family, and a prayer was said in his honor. Mayor Robertson called for a recess for the public to congratulate City Manager Santillan.

RECESS: At 6:17 p.m., Mayor Robertson called for a short break in the meeting. The meeting then reconvened at 6:24 p.m.

Prior to Consent Calendar, Mayor Robertson moved to Item 2, for a Public Hearing, which is to be heard at a specific date and time.

Item 2: Redistricting - Third Public Hearing to Receive Input from the Community Regarding Proposed Draft District Maps, Composition of District Boundaries, and Communities of Interest

Shalice Tilton, NDC Consultant gave the staff report and explained the maps of redistricting. She explained and showed four different maps and explained the changes to the districts. She will return on March 21, 2022, to adopt the redistricting map chosen.

Mayor Robertson asked Council for comments; Council Member Trujillo would like more information on re-numbering the districts.

Mayor Robertson opened the Public Hearing for anyone to speak in favor of or in opposition

to redistricting. Theresa Salas spoke and identified she is the one who provided Map 104. Louis Franco mentioned it is time for the community to submit maps.

Shalice Tilton, Consultant noted that any map provided has to be published 7 days prior to the March 21, public hearing.

Mayor Robertson, seeing no other comments, closed the public hearing.

CONSENT CALENDAR: Motion by Council member Trujillo, seconded by Council member Guerra to approve the Consent Calendar as presented, with one exclusion of Item 1.g. The motion carried unanimously.

Item 1.a: Consideration of the November 1, 2021, Council meeting minutes

Item 1.b: Consideration of the November 12, 2021, Council meeting minutes

Item 1.c: Consideration of the November 15, 2021, Council meeting minutes

Item 1.d: Consideration of the December 6, 2021, Council meeting minutes

Item 1.e: Consideration of the December 21, 2021, Council meeting minutes

Item 1.f: Resolution 2022-6R Authorizing the City to Continue with Teleconferenced Public Meetings Pursuant to Assembly Bill 361

Item 1.g: Award Resolution the Contract for the Community Development Block Grant (CDBG) Project No. 19651 Sidewalk Connectivity Project to Witbro, Inc. DBA Seal Rite Paving and Grading

City Manager Santillan pulled Item 1.g and tabled this item from the Consent Calendar and will be heard at a different City Council meeting.

Item 1.h: Resolution 2022-7R, Fresno Council of Governments (COG) Call for Projects for Congestion Mitigation and Air Quality Improvement Program (CMAQ) and Surface Transportation Block Grant (STBG) Targeted Performance Program (TPP) Applications

Mayor Robertson requested this item 1.h be heard under separate consideration.

Item 1.i: Resolution 2022-8R Waiving Fees for Temporary Rental of Pioneer Village Main Building to Fresno County Department of Public Health for COVID-19 testing.

Item 1.j: Resolution 2022-9R Declaring Surplus and Sale, Donation or Disposal of City Property

Item 1.k: Consideration of the check register dated January 31, 2022

Council member Guerra requested this item 1.k be heard under separate consideration.

Item 1.1: Resolution 2022-10R, Approving and Authorizing the City Manager to Execute a Memorandum of Understanding between the City of Selma and Boys & Girls Club of Fresno County-Selma Club Regarding City Funding

Mayor Robertson requested Item 1.1 be pulled and heard under separate consideration.

Item 3: Consider adoption of a Resolution 2022-11R Approving Side Letter Agreements with the Police Mid-Management Employees and the International Association of Firefighters Local 3716; and Approving the Master Salary Schedule Reflecting Changes in Job Classifications and Pay Rates

Motion by Council member Trujillo, seconded by Council member Mendoza-Navarro to approve Resolution 2022-11R Side Letter Agreements with the Police Mid-Management Unit and the International Association of Firefighters Local 3716; and Approving the Master Salary Schedule Reflecting Changes in Job Classifications and Pay Rates. The motion passed unanimously.

Item 4: Consider Extending the Stay of Enforcement regarding the Removal of an Illegal On-Premises Advertising Display at 1630 2nd Street

Mayor Robertson asked for public comments, Mr. Manderin, property owner requested a 60-day extension.

It was consensus of Council to extend to the property owner a 60-day stay of enforcement of abatement to complete and finalize his development of the property and return the item in the time frame to Council for further direction.

DEPARTMENTAL REPORTS: City Manager Santillan announced and introduced newly hired Deputy City Manager Rob Terry. He also announced an upcoming Special Meeting regarding Infrastructure to begin at 5:00 p.m. in the Council Chambers.

Police Commander Garza reported on personnel and on a recent crime incident.

Community Services Director Kirchner reported American Legion donated \$2,500 to parks to replace damaged equipment.

COUNCIL REPORTS: Council member Mendoza-Navarro attended the Knights of Columbus Valentine's Day dinner.

Council member Trujillo attended a Southeast Regional Solid Waste meeting.

Council member Guerra attended the Knight of Columbus Valentine's Day dinner; she also met with developers Tim Jones and Nick Bruno.

Mayor Pro Tem Cho attended the 34th Annual Blossom trail opening and the Lions Club served at Christian Café. She also discussed the upcoming Chamber of Commerce Crab Feed and the Portuguese Dinner fundraiser.

Mayor Robertson thanked all staff, thanked American Legion Post 12 for the \$2,500 donation for the monkey bars at the park. Mayor Robertson reported that he served at Christian Café; Chaired the Cal Vans subcommittee and attended the COG meeting. He then reported graffiti at the Pro PT Physical Therapy building.

ORAL COMMUNICATIONS: Public comments were received from the following citizens: Mercedes Zamora and Theresa Salas.

ADJOURNMENT: There being no further business, Mayor Robertson adjourned the meeting at 8:04 p.m.

Respectfully Submitted,

Reyna Rivera, City Clerk

**MINUTES
SELMA CITY COUNCIL
SPECIAL MEETING**

Agenda item 2

February 22, 2022

Selma City Council Chambers
1710 Tucker Street
Selma, CA 93662

Call to order: Mayor Robertson called the Special meeting to order at 5:30 p.m.

Roll Call: Present - Council members Guerra, Mendoza-Navarro, Trujillo, Mayor Pro Tem Cho, and Mayor Robertson

Potential Conflicts of Interest: Any Council member who has a potential conflict of interest may now identify the item and recuse themselves from discussing and voting on the matter. No Conflict of Interest was declared.

ORAL COMMUNICATIONS: Mayor Robertson asked for public comments, seeing none, he closed the public comments.

CLOSED SESSION: Mayor Robertson recessed to closed session to hear the following item:

CONFERENCE WITH LABOR NEGOTIATORS - Government Code Section 54957.6

Agency Designated Representatives: City Manager Fernando Santillan, Deputy City Manager Ralph Jimenez
Employee Organization: All Bargaining Groups

Mayor Robertson then reconvened the meeting from closed session at 6:05 p.m. **with no reportable action.**

ADJOURNMENT: There being no further business, Mayor Robertson adjourned the meeting at 6:06 p.m.

Respectfully Submitted,

Reyna Rivera, City Clerk

**MINUTES
SELMA CITY COUNCIL
REGULAR MEETING**

**February 22, 2022
6:00 PM**

Selma City Council Chambers
1710 Tucker Street
Selma, CA 93662

Call to Order: Mayor Robertson called the Regular Session meeting to order at 6:11 p.m.

Invocation led by: Pastor Josue Guevara, Peoples Church of Selma

Pledge of Allegiance led by: Council Member Trujillo

Roll Call: Present - Council Members Guerra, Mendoza-Navarro, Trujillo, Mayor Pro Tem Cho, and Mayor Robertson

Potential Conflicts of Interest: *Any Council Member who has a potential conflict of interest may now identify the item and recuse themselves from discussing and voting on the matter.*

No Conflict of Interest declared.

ORAL COMMUNICATIONS: Mayor Robertson asked for public comments, the following citizens spoke: Cheryl Kain; Char Tucker; Yesenia Espinoza; and Diane Ramos.

Mayor Robertson asked for the Military Banners to be placed on a further agenda for discussion.

CERTIFICATE OF RECOGNITION – BOB ALLEN: Mayor Pro Tem Cho presented a Certificate of Appreciation to Mr. Bob Allen for his years of service and congratulated him on his retirement.

CONSENT CALENDAR: Council member Guerra requested to pull agenda item 1.e. for separate discussion. City Manager Santillan requested to pull agenda item 1.d. Motion was then made by Council member Guerra and seconded by Council member Trujillo to approve items 1.a; 1.b and 1.c as presented. The motion passed unanimously.

- Item 1.a: **Resolution 2022-12R** Reject All Bids received for the Community Development Block Grant Project No. 19651 Sidewalk Connectivity Project and Re-Advertise and Re-Bid Authorization
- Item 1.b: **Resolution 2022-13R** Request by the California League of Cities for Opposition of the Taxpayer Protection and Government Accountability Act or AG# 21-0042A1
- Item 1.c: **Approved** Memorandum of Understanding agreement with the Rape

Counseling Services of Fresno

Item 1.d: **Tabled** Request by Fresno County Economic Development Corporation for a Letter of Support for the Good Jobs Challenge Program Application
This item was pulled from the agenda by City Manager Santillan, with no further approval regarding this item.

Item 1.e: **Approved** Consideration of the check register dated February 16, 2022
This item was pulled by Council member Guerra to be heard under separate motion.

Motion by Council member Trujillo, seconded by Mayor Pro Tem Cho to approve items 1.e as presented. The motion carried unanimously.

Item 2: **APPROVE RESOLUTION THE LOCAL ROAD AND SAFETY PLAN AS PART OF THE MULTIJURISDICTIONAL LOCAL ROAD SAFETY PLAN PREPARED BY THE FRESNO COUNCIL OF GOVERNMENTS**

Yamabe and Horn Engineering Consultant Romero discussed the information for Council. Also in attendance was Matt Braughton, Kittelson & Associates and Jennifer Soliz with Fresno Council of Governments.

Matt Braughton gave a PowerPoint presentation on the Multijurisdictional Local Road Safety Plan.

Mayor Robertson asked for public comments, seeing none, he closed the public comments.

Motion by Council member Mendoza-Navarro, seconded by Mayor Pro Tem Cho to Adopt Resolution 2022-14R, Approving the Local Road and Safety Plan prepared by the Fresno Council of Governments (Fresno COG). The motion carried unanimously.

Item 3: **DOWNTOWN STRATEGIC PLAN FUNDING: DISCUSSION AND UPDATE:** Economic Development Analyst Tosta gave a PowerPoint presentation on the Strategic Plan.

Mayor Robertson asked for public comments, the following spoke: Rose Robertson; Cheryl Kain.

After much discussion, Council thanked Staff for the information. It was stated that this item was information only.

DEPARTMENTAL REPORTS: City Manager Santillan thanked Tracy Tosta for her service to the city. He also introduced the Finance Director Diego Ibanez.

Police Commander Garza reported on a recent crime incident.

COUNCIL REPORTS: Council member Trujillo reported on attending a meeting with Consolidated Irrigation District. He requested the following items re-visited on a future

agenda: Budget item for speakers; Sign policy; vendor policy; and Salary Master Plan report.

Council member Guerra reported she attended the Selma Kingsburg Fowler County Sanitation District meeting and noted the General Manager has retired.

Mayor Pro Tem Cho reported she attended the Five Cities meeting and a job fair will be held tomorrow at the United Shopping Center.

Mayor Robertson reported he attended a Cal Van meeting. He inquired on a water main break and reported on graffiti complaints. He requested a future agenda item to discuss meeting in person moving forward and the homelessness in Selma.

ORAL COMMUNICATIONS: Mayor Robertson asked for public comments, seeing none, he closed the public comments.

ADJOURNMENT: There being no further business, Mayor Robertson adjourned the meeting at 7:59 p.m.

Respectfully submitted,

Reyna Rivera, City Clerk

MINUTES
SELMA CITY COUNCIL
REGULAR MEETING
January 17, 2023

Agenda item 3

Selma City Council Chambers
1710 Tucker Street
Selma, CA 93662

VIA TELECONFERENCE PURSUANT TO AB 361. THE PUBLIC ALSO HAD THE OPTION TO CALL +1 301 715 8592 ID: 891 6864 5005 TO PROVIDE COMMENTS ON AGENDA ITEMS.

The regular meeting of the Selma City Council was called to order at 6:00 p.m. in the Council Chambers and by teleconference. Council members answering roll call were: Guerra, Mendoza-Navarro, Trujillo, Mayor Pro Tem Cho and Mayor Robertson.

INVOCATION: Pastor Jose Alvarez of Iglesia Antioquia led the invocation. A moment of Silence was held in honor of Pastor Gene Smith and Mrs. Velma Quintana.

The Pledge of Allegiance was led by Council Member Guerra.

Oral Communications: Mr. Jim Avalos and Ms. Anita Gonzalez stepped forward to address Council.

2023-1R **CONSIDER APPROVAL OF RESOLUTION CERTIFYING NOVEMBER 8, 2022 GENERAL ELECTION:** Council member Guerra motioned to approve RESOLUTION NO. 2023-1 CERTIFYING THE NOVEMBER 8, 2022 GENERAL ELECTION. The motion was seconded by Council member Mendoza-Navarro and carried unanimously.

PRESENTATION OF OATH OF OFFICE TO NEWLY ELECTED MAYOR SCOTT ROBERTSON AND COUNCIL MEMBERS DISTRICT 2 JOHN TRUJILLO, DISTRICT 3 SARAH GUERRA: City Clerk Rivera administered the Oath of Office to newly elected Mayor Scott Robertson and Council members John Trujillo and Sarah Guerra.

PRESENTATION OF CERTIFICATES OF ELECTION: City Clerk Rivera presented the Certificates of Election to newly elected Mayor Scott Robertson and Council members John Trujillo and Sarah Guerra.

SELECTION OF MAYOR PRO TEMPORE PER ORDINANCE NO. 2020-1: City Clerk Rivera reported that under the provisions of Selma Ordinance No. 2020-1, there is an established procedure for the selection of the Mayor Pro Tempore.

Motion was made by Council member Trujillo to appoint Council Member Cho as Mayor Pro Tem and was seconded by Council Member Mendoza-Navarro. The motion carried unanimously.

COMMENTS FROM CITY COUNCIL: At this point in the meeting, each Council member thanked their constituents for their support.

SPECIAL PRESENTATIONS: Deputy City Manager Bains introduced Public Works Director Alvin Dias, Finance Accountant Andrea Gonzalez and City Manager Megan Dodd.

RECESS: At 6:27 p.m., Mayor Robertson called for a short break in the meeting. The meeting then reconvened at 6:40 p.m.

CONSENT CALENDAR: Mayor Robertson requested to pull item 5 and stated that a member of the public requested to pull agenda item 3. Council member Guerra requested to pull item 6 for separate discussion. Motion was then made by Council member Guerra to approve the remainder of the Consent calendar as written. Motion was seconded by Council member Trujillo and carried unanimously.

2023-2R **CONSIDER LEGAL SERVICES AGREEMENT WITH GRISWOLD, LASALLE, COBB, DOWD & GIN LLP**

2023-3R **CONSIDER APPROVAL OF A RESOLUTION FOR THE ADOPTION OF A RECORDS MANAGEMENT POLICY CONTAINING CERTAIN RECORDS RETENTION SCHEDULES AND RECORDS DESTRUCTION GUIDELINES:** Public comment was received by Mr. Jim Avalos. After discussion, motion was made by Council member Trujillo and seconded by Mayor Pro Tem Cho. The motion then carried unanimously.

2023-4R **CONSIDERATION OF DEFERRED IMPROVEMENTS AND ENFORCEMENT AGREEMENT BETWEEN THE CITY OF SELMA AND DAWSON-MAULDIN, LLC**

2023-1 **FIRST READING OF AN ORDINANCE OF THE CITY OF SELMA AMENDING SECTION 1-13-1 OF TITLE I OF THE SELMA MUNICIPAL CODE RELATING TO THE CITY'S PURCHASING SYSTEM AND DELETING SECTIONS 1-13-2 THROUGH 1-13-10 OF THE TITLE I OF THE SELMA MUNICIPAL CODE:** Public comment was received by Mr. Jim Avalos and Mrs. Rose Robertson. After discussion, motion was made by Council member Trujillo to APPROVE AND WAIVE THE FIRST READING OF ORDINANCE 2023-1 AMENDING SECTION 1-13-1 OF TITLE 1 OF THE SELMA MUNICIPAL CODE RELATING TO THE CITY'S PURCHASING SYSTEM AND DELETING SECTIONS 1-13-2 THROUGH 1-13-10 OF THE TITLE 1 OF THE SELMA MUNICIPAL CODE. Motion was seconded by Council member Mendoza-Navarro. The motion carried by the following vote:

AYES: Trujillo, Mendoza-Navarro, Cho
NOES: Guerra, Robertson

Approved **CHECK REGISTER DATED JANUARY 17, 2023:** After discussion, motion was made by Council member Trujillo to APPROVE CHECK REGISTER DATED JANUARY 17, 2023. The motion was seconded by Council member Guerra and carried unanimously.

Approved **CONSIDER MAYORAL/CITY COUNCIL APPOINTMENTS TO VARIOUS BOARDS:** City Attorney Dodd discussed the process for appointments to Boards, Committees, and Commissions as determined by statute or by the Joint Powers Agreement.

Motion was made by Council member Trujillo and seconded by Council member Mendoza-Navarro to nominate Mayor Pro Tem Cho as the Five Cities Economic Development Authority Board of Directors. The motion carried unanimously.

Motion was made by Council member Mendoza-Navarro and seconded by Council member Trujillo to nominate Council member Mendoza-Navarro as the Alternate Fresno Council of Governments Board of Director. Motion carried unanimously.

Motion was made by Council member Trujillo and seconded by Council member Mendoza-Navarro to nominate Mayor Robertson as the Fresno County Rural Transit Agency Board of Directors. Motion carried unanimously.

Motion was made by Council member Trujillo and seconded by Mayor Pro Tem Cho to nominate Council member Mendoza-Navarro as the Fresno County Rural Transit Agency Alternate Board of Director. Motion carried unanimously.

Motion was made by Council member Trujillo to nominate Council member Guerra as the Upper Kings Basin Integrated Regional Water Management Authority Board of Director. Council member Guerra declined the nomination. The motion did not carry.

Motion was made by Council member Trujillo and seconded by Mayor Pro Tem Cho to nominate Council member Mendoza-Navarro as the Alternate Selma-Kingsburg-Fowler Sanitation District (SKF) Board of Director. The motion carried with the following vote:

AYES: Trujillo, Cho, Mendoza-Navarro
NOES: Guerra, Robertson

Motion was made by Council member Mendoza-Navarro and seconded by Council member Guerra to nominate Mayor Pro Tem Cho as the Upper Kings Basin Integrated Regional Water Management Authority Board of Director. The motion carried with the following vote:

AYES: Mendoza-Navarro, Guerra, Trujillo, Cho
NOES: Robertson

Mayor Robertson requested the additional appointments at a future meeting agenda.

2023-5R

CONSIDERATION OF INCREASE TO FISCAL YEAR 2022-2023 FOR ONE FULL-TIME INFORMATION TECHNOLOGY TECHNICIAN EMPLOYEE POSITION: Deputy City Manager Bains reported on the request of the addition of a new position and the impact to the general fund. After discussion, motion was made by Council member Guerra and seconded by Council member Mendoza-Navarro to adopt RESOLUTION NO. 2023-5R APPROVING ONE FULL TIME EMPLOYEE POSITION TO DATA PROCESSING. The motion carried unanimously.

2023-6R

CONSIDER APPROVAL OF AN AGREEMENT FOR CITY OF SELMA POLICE DEPARTMENT TO CONTRACT WITH THE FRESNO COUNTY PROBATION DEPARTMENT FOR A POLICE OFFICER TO THE FRESNO COUNTY PROBATION AND PAROLE ADULT COMPLIANCE TEAM (ACT): Police Chief Alcaraz reported on the agreement with the County of Fresno. After discussion, public comment was received from Mr. Jim Avalos. Motion was then made by Council member Guerra and seconded by Council member Mendoza-Navarro to approve RESOLUTION NO. 2023-6R AUTHORIZING THE CITY MANAGER TO EXECUTE AN AGREEMENT FOR CITY OF SELMA POLICE DEPARTMENT TO CONTRACT WITH THE FRESNO COUNTY PROBATION DEPARTMENT FOR A POLICE OFFICER ASSIGNMENT TO THE FRESNO COUNTY PROBATION AND PAROLE ADULT COMPLIANCE TEAM (ACT).

DEPARTMENTAL REPORTS: Public Works Director Dias provided updates on the City Hall remodel project and the Salazar Center project. He discussed the weather related concerns and congratulated Fernando Moran on his 15th year of service to the City.

Fire Division Chief Fullner reported on the recent loss of retired Fire Chief Roy Peak.

Police Chief Alcaraz discussed the policy change for facial hair and tattoos within his department and the speed bump project.

Community Services Director Smart personally thanked our Public Safety Personnel. She updated Council on the recent Arts Center Show, Shafer Park restroom project, and the upcoming Chamber mixer.

COUNCIL REPORTS: Council member Mendoza-Navarro welcomed the new employees and City Attorney Dodd. She inquired on the signal light turn signal for the intersection of Thompson and Dinuba Avenues. She reported on the recent loss of Glenn Alves and thanked the Fire Department for their service.

Council member Trujillo welcomed City Attorney Dodd and the new employees. He thanked Selma Cares for their service and his spouse for attending today's meeting. He then requested at a future agenda the discussion of the code of conduct.

Council member Guerra thanked city staff for their service. She inquired on the trees at the shopping center near Floral and Whitson.

Mayor Pro Tem Cho welcomed the new employees and wished everyone a Happy New Year.

Mayor Robertson reported on attending the following: Central Valley Training Center graduation, food distribution at the Gurdwara Guru Kalgidhar Sahib, which is near the bowling alley. He requested at a future agenda the discussion of the Capital Improvement Plan and discussed the upcoming Cal Vans stakeholder meeting.

ORAL COMMUNICATIONS: Public comment was received from Mr. Isaac Garza, Mr. Jim Avalos, Mr. Michael Rivera, and Mrs. Anita Gonzalez.

ADJOURNMENT: There being no further business, Mayor Robertson adjourned the meeting at 8:34 p.m.

Respectfully submitted,

Reyna Rivera, City Clerk

**MINUTES
SELMA CITY COUNCIL
SPECIAL MEETING
February 6, 2023**

Agenda item 4

Selma City Council Chambers
1710 Tucker Street
Selma, CA 93662

*VIA TELECONFERENCE PURSUANT TO AB 361. THE PUBLIC ALSO HAD THE OPTION TO CALL +1 301 715
8592 ID: 891 6864 5005 TO PROVIDE COMMENTS ON AGENDA ITEMS.*

The special meeting of the Selma City Council was called to order at 5:00 p.m. in the Council Chambers and by teleconference. Council members answering roll call were: Mendoza-Navarro, Trujillo, and Mayor Pro Tem Cho. Council member Guerra and Mayor Robertson were absent.

CLOSED SESSION: Mayor Pro Tem Cho recessed the meeting into Closed Session at 5:04 p.m. to discuss the following:

CONFERENCE WITH LABOR NEGOTIATORS

Government Code Section 54957.6

Agency designated representatives: City Attorney Megan Dodd

Employee Organization: City Manager

CONFERENCE WITH REAL PROPERTY NEGOTIATORS:

Government Code Section 54956.8

Property: APN 358-080-79

Agency Negotiator: Selma City Manager Fernando Santillan

Negotiating Parties: McKenry

Under Negotiation: Instructions to City's negotiator may concern sale of property, price, terms and conditions

Mayor Pro Tem Cho reconvened the meeting from closed session at 5:26 p.m. City Attorney Dodd stated that there was no reportable action.

ADJOURNMENT: There being no further business, the meeting was adjourned at 5:27 p.m.

Respectfully submitted,

Reyna Rivera, City Clerk

**MINUTES
SELMA CITY COUNCIL
REGULAR MEETING
February 6, 2023
6:00 p.m.**

Selma City Council Chambers
1710 Tucker Street
Selma, CA 93662

VIA TELECONFERENCE PURSUANT TO AB 361. THE PUBLIC ALSO HAD THE OPTION TO CALL +1 301 715 8592 ID: 891 6864 5005 TO PROVIDE COMMENTS ON AGENDA ITEMS.

The regular meeting of the Selma City Council was called to order at 6:00 p.m. in the Council Chambers and by teleconference. Council members answering roll call were: Mendoza-Navarro, Trujillo, and Mayor Pro Tem Cho. Council member Guerra and Mayor Robertson were absent.

INVOCATION: Pastor Gilbert Zapata Jr., Selma Church of God led the invocation. A moment of Silence was held in honor of Fallen Police Officer Gonzalo Carrasco.

The Pledge of Allegiance was led by Council member Mendoza-Navarro.

AGENDA CHANGES OR DELETIONS: To better accommodate members of the public or inconvenience in the order of presentation, items on the agenda may not be presented or acted upon in the order listed. Additions to Agenda may be added only pursuant to California Government Code Section 54954.2 (b). Mayor Pro Tem Cho requested that agenda items #6, #7, #8, #9, #10 would be pulled from the agenda and placed at a future agenda. Council member Mendoza-Navarro seconded the request to pull the agenda items and place at a future. The motion carried by the following vote:

AYES: Cho, Mendoza-Navarro, Trujillo

ABSENT: Guerra, Robertson

CONSENT CALENDAR: Motion was made by Council member Trujillo to approve the Consent calendar as written. Motion was seconded by Council member Mendoza-Navarro and carried by the following vote:

AYES: Trujillo, Mendoza-Navarro, Cho

ABSENT: Guerra, Robertson

2023-7R **CONSIDER APPROVAL OF A RESOLUTION DECLARING CERTAIN CITY PROPERTY SURPLUS AND AUTHORIZING THEIR SALE, DONATION OR DISPOSAL**

2023-8R **CONSIDERATION OF A RESOLUTION AUTHORIZING THE CITY TO CONTINUE WITH TELECONFERENCE PUBLIC MEETINGS PURSUANT TO ASSEMBLY BILL 361**

2023-9R **CONSIDERATION OF A RESOLUTION AUTHORIZING THE PARTICIPATION IN THE COMMUNITY DEVELOPMENT BLOCK GRANT (“CDBG”) PROGRAM FOR 2024-25, 2025-26 AND 2026-27**

Approved **CHECK REGISTER DATED JANUARY 30, 2023**

2023-1 **SECOND READING, PUBLIC HEARING, AND ADOPTION OF AN ORDINANCE OF THE CITY OF SELMA AMENDING SECTION 1-13-1 OF TITLE I OF THE SELMA MUNICIPAL CODE RELATING TO THE CITY'S PURCHASING SYSTEM AND DELETING SECTIONS 1-13-2 THROUGH 1-13-10 OF THE TITLE I OF THE SELMA MUNICIPAL CODE:** Deputy City Manager Bains reported on the proposed amendment and purchasing policy with amendments made to include language to satisfy State and Federal requirements.

Mayor Pro Tem Cho opened the public hearing at 6:07 p.m. There being no comments, Mayor Pro Tem Cho closed the public hearing at 6:08 p.m.

After discussion, motion was made by Council member Trujillo and seconded by Council member Mendoza-Navarro to adopt ORDINANCE NO. 2023-1 AMENDING SECTION 1-13-1 OF TITLE I OF THE SELMA MUNICIPAL CODE RELATING TO THE CITY'S PURCHASING SYSTEM AND DELETING SECTIONS 1-13-2 THROUGH 1-13-10 OF THE TITLE I OF THE SELMA MUNICIPAL CODE. The motion carried with the following vote:

AYES: Trujillo, Mendoza-Navarro, Cho
ABSENT: Guerra, Robertson

2023-10R **RESOLUTION APPROVING THE FINANCE PURCHASING DIVISION PURCHASING AND CONTRACT PROCEDURES:** After discussion, motion was made by Council member Mendoza-Navarro and seconded by Council member Trujillo to adopt RESOLUTION 2023-10R APPROVING THE FINANCE PURCHASING DIVISION PURCHASING AND CONTRACT PROCEDURES. The motion carried with the following vote:

AYES: Mendoza-Navarro, Trujillo, Cho
ABSENT: Guerra, Robertson

Pulled **DISCUSSION REGARDING COMMEMORATION OF FALLEN OFFICER GONZALO CARRASCO:** This item was pulled.

Pulled **CONSIDER MAYORAL/CITY COUNCIL APPOINTMENTS TO VARIOUS BOARDS:** This item was pulled.

Pulled **DISCUSSION REGARDING STATE AND FEDERAL BUDGET APPROPRIATIONS AND LEGISLATIVE FUNDING PRIORITIES FOR THE CITY OF SELMA:** This item was pulled.

Pulled **DISCUSSION REGARDING CITY COUNCIL CODE OF CONDUCT PER COUNCIL'S REQUEST:** This item was pulled.

Pulled **DISCUSSION REGARDING CLARIFICATION OF THE CENTRAL VALLEY LIONESS LIONS CLUB 11TH ANNUAL SENIOR THANKSGIVING MEAL EXPENSES AND REIMBURSEMENTS:** This item was pulled.

Approved **CONSIDER APPROVAL OF AMENDMENTS TO CITY MANAGER EMPLOYMENT AGREEMENT:** City Attorney Dodd reported on the proposed amendments for Council consideration. After discussion, motion was made by Council member Mendoza-Navarro and seconded by Council member Trujillo to approve the AMENDMENT TO CITY MANAGER EMPLOYMENT AGREEMENT. The motion carried with the following vote:

AYES: Mendoza-Navarro, Trujillo, Cho
ABSENT: Guerra, Robertson

DEPARTMENTAL REPORTS: City Manager Santillan reported that the next Council meeting will be held on Tuesday, February 21, 2023, due to the holiday on Monday, February, 20, 2023.

Deputy City Manager Bains updated Council on policies and recruitments.

Police Chief Alcaraz thanked everyone for the continued support and prayers during this time.

Community Services Director Smart reminded everyone to view the Arts Center website for upcoming events.

Public Works Director Dias updated Council on the City Hall remodel project, Shafer Park restroom project, and Lincoln Park project.

COUNCIL REPORTS: Council member Mendoza-Navarro thanked Police Chief Alcaraz, staff, and nation for their response during this time.

Council member Trujillo requested prayers to the Carrasco family and thanked staff and the community.

Mayor Pro Tem Cho reported on attending a recent vigil held for Fallen Police Officer Carrasco. She also announced the upcoming viewing and ceremony.

ORAL COMMUNICATIONS: Public comment was received from Mr. Manuel Guido.

ADJOURNMENT: There being no further business, Mayor Pro Tem Cho adjourned the meeting at 6:30 p.m.

Respectfully submitted,

Reyna Rivera, City Clerk

**CITY MANAGER'S/STAFF'S REPORT
COUNCIL MEETING DATE:**

March 20, 2023

ITEM NO: 5.

SUBJECT: Consideration of a Resolution Accepting a Grant Deed from Harris Ranch Beef Company for Real Property.

BACKGROUND: Harris Ranch Beef Company is issuing a grant deed for land necessary for the expansion of the Clarkson Sewer Lift Station. The land is on the West side of McCall Avenue south of Clarkson Avenue. Additional land is required to accommodate the expansion of the Clarkson Lift Station.

DISCUSSION: The improvements required to expand the Clarkson Lift Station will require additional land north of the existing facility. The adjacent parcel previously owned by the City of Selma was granted to the Harris Beef Company in 2015. The proposed expansion requires an additional piece of land that is 35-foot wide. Prior to submitting the Clarkson Lift Station Project for public bid and construction, the City of Selma will need to own the land in Fee.

Conditions are included in the Resolution as recommendations to verify that no Title Exceptions exist on the portion of the land being Granted to the City of Selma. Once the City Manager and City Attorney are satisfied with a clear Title, the Clerk will be instructed to deliver the Grant Deed for recording.

FISCAL IMPACT: No fiscal impact.

RECOMMENDATION: Adoption of resolution, approval by motion to accept the land granted to the City of Selma for the purpose of a Sewer Lift Station, and direct City Clerk to submit the Grant Deed to the Fresno County Recorder's office.

_____/s/
David Horn
City Engineer

_____March 15, 2023
Date

_____/s/
Fernando Santillan
City Manager

_____March 15, 2023
Date

Attachments:

1. Resolution No. 2023- _____
2. Grant Deed

RESOLUTION NO. 2023-__

**A RESOLUTION OF THE CITY COUNCIL OF THE CITY OF SELMA,
CALIFORNIA ACCEPTING REAL PROPERTY FOR PUBLIC PURPOSES FROM
HARRIS RANCH BEEF COMPANY FOR THE CLARKSON LIFT STATION
EXPANSION**

WHEREAS, the City intends to expand the existing Clarkson Lift Station on McCall Avenue south of Clarkson Avenue; and,

WHEREAS, the proposed expansion requires approximately 4,375 square feet of land immediately adjacent to the existing Clarkson Lift Station; and,

WHEREAS, Harris Ranch Beef Company, a California Company, (“Property Owner”) owns the adjacent parcel of land designated as APN 393-114-18 agrees to deed the necessary land to the City of Selma; and,

WHEREAS, property acquisition is needed to secure land rights for the expansion of the sewer lift station improvements; and,

WHEREAS, the Grant Deed of a portion of the property designated as APN 393-114-18 was prepared in acceptable form and content and the Property Owner has executed the Grant Deed for this property, attached hereto as Attachment 1, which will convey this property to the City of Selma; and,

WHEREAS, the City Council has determined that the acceptance of the Grant Deed would be in the public interest; and,

WHEREAS, there are certain conditions (“Consummation Conditions”) which must be satisfied prior to the recording of the Grant Deed, including securing a title insurance policy and clearing certain exceptions to title, which conditions will be confirmed by the City Manager and City Attorney.

NOW, THEREFORE, BE IT RESOLVED that the City Council of the City of Selma hereby finds, determines, and declares the following:

1. The above recitals are true and correct;
2. Accepts that certain Grant Deed executed by Brian Coelho on the 2nd day of March, 2023 as described hereinabove and attached hereto;
3. Authorizes and directs City Clerk to sign and deliver a Certificate of Acceptance upon completion of the Consummation Conditions to the satisfaction of the City Manager and City Attorneys.
4. **Section 4. Severability.** The provisions of this Resolution are severable and if any provision, clause, sentence, word or part thereof is held illegal, invalid, unconstitutional, or inapplicable to any person or circumstances, such illegality, invalidity, unconstitutionality, or inapplicability shall not affect or impair any of the

remaining provisions, clauses, sentences, sections, words or parts thereof of the Resolution or their applicability to other persons or circumstances.

5. **Section 5. Effective Date.** That the City Clerk shall certify to the adoption of this Resolution and that the same shall be in full force and effect.

The foregoing Resolution was approved and adopted at a regular meeting of the City Council of the City of Selma held on the 20th day of March, 2023 by the following vote:

AYES: COUNCIL MEMBERS:
NOES: COUNCIL MEMBERS:
ABSTAIN: COUNCIL MEMBERS:
ABSENT: COUNCIL MEMBERS:

Scott Robertson
Mayor

ATTEST:

Reyna Rivera
City Clerk

FOR THE BENEFIT OF THE
CITY OF SELMA
FREE RECORDING IN ACCORDANCE
OF CALIFORNIA Govt. Code Sections
6103 and 27383

WHEN RECORDED MAIL TO AND,
REQUESTED BY:
CITY OF SELMA
1710 TUCKER STREET
SELMA, CA 93662
FRESNO COUNTY
ATTN: CITY CLERK

APN: 393-141-18

SPACE ABOVE THIS LINE FOR RECORDER'S USE

PROPERTY ADDRESS:
Near SW Cor Clarkson & McCall
Por. Parcel 1 of Parcel Map No. 26

Documentary transfer tax is \$ 0
(X) Unincorporated area : () City of Selma

GRANT DEED

FOR A VALUABLE CONSIDERATION, receipt of which is hereby acknowledged,

HARRIS RANCH BEEF COMPANY, A CALIFORNIA CORPORATION

hereby GRANT IN FEE for Sewer Lift Station purposes to the CITY OF SELMA, a California Municipal Corporation, the following described Real Property in the County of Fresno, State of California, to wit:

SEE EXHIBITS "A" & "B" ATTACHED

HARRIS RANCH BEEF COMPANY, A CALIFORNIA CORPORATION

BY: 

Brian Coelho, CEO

DATE: 3/2/23

ATTACH NOTARY ACKNOWLEDGEMENT

Exhibit "A"

Legal Description

The land described herein is situated in the County of Fresno, State of California, and is described as follows:

The north 35.00 feet of the south 83.00 feet of Parcel 1 of Parcel Map No. 26 recorded in Book 18 of Parcel Maps at Page 48, Fresno County Records.

Containing 4,375 square feet, more or less.



3-2-23

NORTHEAST CORNER OF SECTION 31 16/22
EAST CLARKSON AVENUE

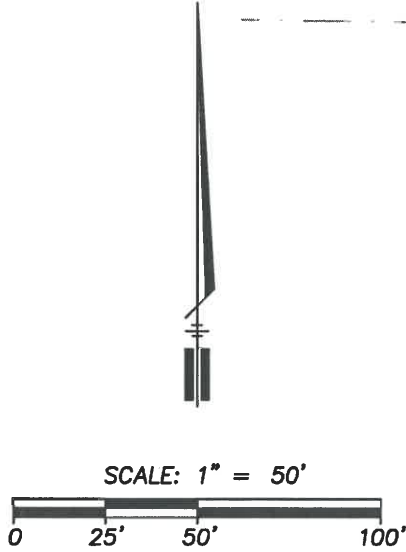

PARCEL 2
 PM NO. 26
 18/PM/48

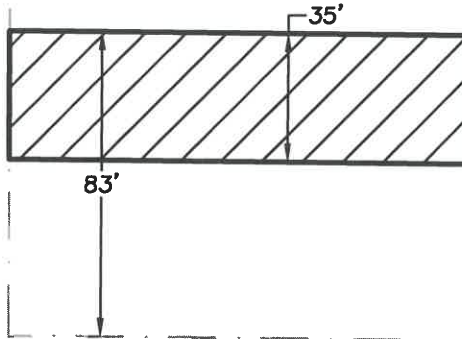

PARCEL 1
 PM NO. 26
 18/PM/48





SOUTH McCALL AVENUE

SOUTHEAST CORNER OF THE NORTHEAST
 QUARTER OF THE NORTHEAST QUARTER OF
 SECTION 31 16/22

LEGEND:

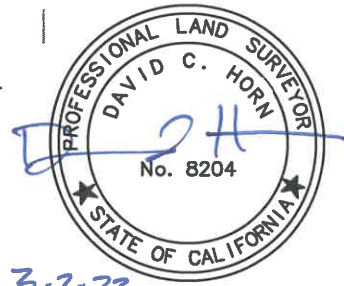
-  AREA TO BE GRANTED TO CITY OF SELMA
 AREA = 4,375± S.F.
-  EXISTING SECTION LINE
-  EXISTING PROPERTY LINE/RIGHT OF WAY LINE



 <p>Yamabe & Horn Engineering, Inc. CIVIL ENGINEERS • LAND SURVEYORS <small>2985 N. BURL AVENUE SUITE 101 FRESNO, CA 93727 TEL: (559) 244-3123 WEBSITE: YANDHENG.COM</small></p>	PROJECT TITLE	EXHIBIT "B"	Date: <u>1/17/2023</u>
	SHEET DESCRIPTION	CLARKSON LIFT STATION	Scale: As Noted YH Job No. <u>22-148</u> Sheet No. <u>1</u> of <u>1</u> Sheets

CALIFORNIA ACKNOWLEDGMENT

CIVIL CODE § 1189

A notary public or other officer completing this certificate verifies only the identity of the individual who signed the document to which this certificate is attached, and not the truthfulness, accuracy, or validity of that document.

State of California }
County of Kings }

On March 2, 2023 before me, Bridgette Bernice Mattos, Notary Public,
Date Here Insert Name and Title of the Officer

personally appeared Brian Coelho
Name(s) of Signer(s)

who proved to me on the basis of satisfactory evidence to be the person(s) whose name(s) is/are subscribed to the within instrument and acknowledged to me that he/she/they executed the same in his/her/their authorized capacity(ies), and that by his/her/their signature(s) on the instrument the person(s), or the entity upon behalf of which the person(s) acted, executed the instrument.

I certify under PENALTY OF PERJURY under the laws of the State of California that the foregoing paragraph is true and correct.

WITNESS my hand and official seal.



Place Notary Seal and/or Stamp Above

Signature B. Mattos
Signature of Notary Public

OPTIONAL

Completing this information can deter alteration of the document or fraudulent reattachment of this form to an unintended document.

Description of Attached Document

Title or Type of Document: Grant Deed

Document Date: _____ Number of Pages: _____

Signer(s) Other Than Named Above: _____

Capacity(ies) Claimed by Signer(s)

Signer's Name: _____ Signer's Name: _____

Corporate Officer – Title(s): _____ Corporate Officer – Title(s): _____

Partner – Limited General Partner – Limited General

Individual Attorney in Fact Individual Attorney in Fact

Trustee Guardian or Conservator Trustee Guardian or Conservator

Other: _____ Other: _____

Signer is Representing: _____ Signer is Representing: _____

**CITY MANAGER'S/STAFF'S REPORT
COUNCIL MEETING DATE:**

March 20, 2023

ITEM NO: 6.

SUBJECT: Consideration of a Resolution Approving a Side Letter to the Current Memorandum of Understanding (MOU) Between the City of Selma and the Fire Mid-Management Unit.

BACKGROUND: Currently, the Fire Division Chiefs are assigned to a 40-hour per week work schedule. As such, their MOU stipulates that they accrue vacation hours according to that schedule, with 8 hours equaling one day of vacation.

DISCUSSION: As the Fire Department has grown over the past several years, it has become necessary to assign a Division Chief to each shift. This will provide for the safety and accountability of the twelve to fifteen fire and EMS personnel that are on duty each day. It will mean that the Division Chief's will switch from a 40-hour workweek to the same 48/96 schedule that all of our other firefighters work. With Council's recent approval of the third Division Chief position, the fire department will be able to implement this change in the coming months. This schedule change requires the approval of a side letter that addresses vacation hours accrued in the current MOU to be the same as other fire department employees working the 48/96 schedule; whereas, 24 hours equals one day of vacation.

FISCAL IMPACT: None

RECOMMENDATION: Adoption of the Resolution Approving the Attached Exhibit A Side Letter to the Current MOU between the City of Selma and the Fire Mid-management Unit.

_____/s/
Robert Petersen
Fire Chief

March 16, 2023
Date

_____/s/
Fernando Santillan
City Manager

March 16, 2023
Date

Attachments:

1. Exhibit A Side Letter
2. Resolution No. 2023- _____

RESOLUTION NO. 2023-__

**A RESOLUTION OF THE CITY COUNCIL OF THE CITY OF SELMA,
CALIFORNIA APPROVING EXHIBIT A SIDE LETTER TO THE CURRENT
MEMORANDUM OF UNDERSTANDING BETWEEN THE CITY OF SELMA AND
THE FIRE MID-MANAGEMENT UNIT**

WHEREAS, the Fire Division Chiefs currently work a 40-hour workweek and accrue vacation hours as such; and,

WHEREAS, the Fire Division Chiefs will be switching to a 48/96 work schedule; and,

WHEREAS, the current Memorandum of Understanding between the City of Selma and the Fire Mid-Management Unit will need to be adjusted to allow for vacation hours to be accrued according to the new schedule; and,

NOW, THEREFORE, BE IT RESOLVED that the City Council of the City of Selma hereby finds, determines, and declares the following:

SECTION 1. The above recitals are true and correct;

SECTION 2. The City Council hereby approves the attached Exhibit A to the current Memorandum of Understanding between the City of Selma and the Fire Mid-Management Unit.

SECTION 3. The City Manager is authorized to execute all necessary documents.

SECTION 4. Severability. The provisions of this Resolution are severable and if any provision, clause, sentence, word or part thereof is held illegal, invalid, unconstitutional, or inapplicable to any person or circumstances, such illegality, invalidity, unconstitutionality, or inapplicability shall not affect or impair any of the remaining provisions, clauses, sentences, sections, words or parts thereof of the Resolution or their applicability to other persons or circumstances.

SECTION 5. Effective Date. That the City Clerk shall certify to the adoption of this Resolution and that the same shall be in full force and effect.

The foregoing Resolution was approved and adopted at a regular meeting of the City Council of the City of Selma held on the 20th day of March 2023, by the following vote:

AYES: COUNCIL MEMBERS:
NOES: COUNCIL MEMBERS:
ABSTAIN: COUNCIL MEMBERS:
ABSENT: COUNCIL MEMBERS:

(Signatures Available on following page)

Scott Robertson
Mayor

ATTEST:

Reyna Rivera
City Clerk

Association Proposal 1

Subject: Vacation Leave

Interest: Division Chiefs are switching from a forty (40) hour employee to a fifty-six (56) hour employee. This side letter is to correct MOU language so Division Chiefs earn vacation leave at the accrual rate of a fifty-six (56) hour employee.

Proposal:

The Association proposes modifying memorandum of understanding as follows:

ARTICLE 15-VACATION:

"Section 1. ANNUAL VACATION LEAVE" of "RULE XIV.LEAVE REGULATIONS" of the adopted Personnel Rules and Regulations of the City of Selma shall be used for determining vacation benefits for Unit employees. If the Personnel Rules and Regulations are amended, the resulting rule shall prevail.

~~A. All Unit Employees except Fire Captains shall accrue vacation according to the following schedule:~~

<u>Years of Service</u>	<u>Number of Days/Month</u>	<u>Number of Days/Year</u>
0-4	1.0	12
5-9	1.5	18
10-14	1.75	21
15 & over	2.0	24

~~1. Unit employees as defined in Article A shall be allowed to accrue up to a maximum of 360 hours of vacation leave.~~

B.A. Unit Employees ~~employed as Fire Captains~~ shall earn and use vacation credits as follows:

City of Selma
and the
Selma Firefighters' Association
Side Letter

Passed
Time: _____
Date: _____

Years of Number of Service <u>Hours/Month</u>	Number of <u>Hours/Year</u>	
1-4 inclusive	12	144
5-9 inclusive	18	216
10-14 inclusive	21	252
15 and over	24	288

1. Unit employees as defined in Article C shall be allowed to accrue up to a maximum of 682.5 hours of vacation leave.

ARTICLE 16- VACATION BUY BACK

- A. Unit employees who have taken a minimum of 80 hours of Vacation Leave (120 hours for Fire Captains) during the previous calendar year will be eligible for Vacation Buy-Back of up to twenty (20) hours per year.
 1. City will notify each employee by February 15 of each calendar year of eligibility to buy back vacation hours. Employee will have the option to receive payment for selected amount of vacation leave hours or decline this benefit. Eligible employees who choose to sell back their vacation leave hours will receive payment before March 31 of the calendar year.

For the City :

For the Association:

Name

Name

CHECK REGISTER REPORT

CHECK NUMBER	CHECK DATE	STATUS	VENDOR NAME	CHECK DESCRIPTION	CATEGORY	AMOUNT
81284	03/09/23	Printed	A-C ELECTRIC COMPANY	PW -INSTALL NEW POWER SUPPLY TRAFFIC SIGNAL THOMPSON/WHIT		1,076.80
81285	03/09/23	Printed	RUDY ALCARAZ	PD -2023 ANNUAL CPCA TRAINING PER DIEM 3/12-3/16/23		325.00
81286	03/09/23	Printed	ALLSTAR FIRE EQUIPMENT	FD -FLATHEAD AXES		231.42
81287	03/09/23	Void		Void Check		0.00
81288	03/09/23	Printed	ARAMARK UNIFORM	UNIFORMS/TOWELS/FIRST AID KITS 2/2-2/9/23		564.58
81289	03/09/23	Printed	AT&T	TELEPHONE -FEBRUARY 2023		35.79
81290	03/09/23	Printed	AT&T	PD -FIRE ALARM		248.80
81291	03/09/23	Printed	BENNY BACA / COOL AIR SPECIALTY	FD -INSTALL 10KW HEATSTRIPS AT FIRE ADMIN		840.00
81292	03/09/23	Printed	JAY WESLEY BROCK / TOP DOG TRAINING	PD -K9 MAINTENANCE 2/20/23		90.00
81293	03/09/23	Printed	CENTRAL SANITARY SUPPLY, LLC.	PW -JANITORIAL SUPPLIES		948.63
81294	03/09/23	Printed	CISCO SYSTEMS CAPITAL CRP	ADMIN -PHONE SYSTEM LEASE		1,375.84
81295	03/09/23	Printed	COOK'S COMMUNICATION CORP	FD -RADIO REPAIRS		95.00
81296	03/09/23	Printed	DATAPATH LLC	ADMIN -NETCARE/ON SITE SUPPORT MARCH 2023, FD-WIRELESS P2P FROM CITY HALL STATION 1, ADMIN -LAPTOP & DOCKING STATION, ADMIN -UPS REPLACEMENTS DOWN PAYMENT		14,779.35
81297	03/09/23	Printed	AJAY DAVIS	ART C -SHE KILLS MONSTERS SOUND ENGINEERING		400.00
81298	03/09/23	Printed	DEPARTMENT OF HEALTH CARE	FD -GEMT QAF 2022 3RD QRT		24,800.58
81299	03/09/23	Printed	VERONICA DUENAS	PD -DONATION PROCEEDS FOR OFFICER CARRASCO		1,615.00
81300	03/09/23	Printed	JOEL A FEDOR / FEDOR PLUMBING	PD -INSTALLED NEW DRINKING FOUNTAIN		1,367.79
81301	03/09/23	Printed	FIRE RECOVERY EMS LLC	FD -AMBULANCE BILLING		269.93
81302	03/09/23	Printed	FRESNO COUNTY CLERK	CITY CLERK -2022 GENERAL ELECTION		6,234.89
81303	03/09/23	Printed	FRESNO COUNTY EDC	FIN -CENTRAL VALLEY TRAINING CENTER 11/1-11/30/22 & OCT 2022 SUPPLEMENTAL	R	58,181.90
81304	03/09/23	Printed	FRESNO COUNTY TAX COLLECTOR	PROPERTY TAX/SEWER 2nd INSTALL 2022/2023		4,340.64
81305	03/09/23	Printed	FRESNO COUNTY TREASURER	REC -SHAFER PARK CONCESSION		890.00
81306	03/09/23	Printed	FRESNO ECONOMIC OPPORTUNITIES	SENIOR C -ONSITE SUPPLIES JANUARY 2023		3,408.90
81307	03/09/23	Printed	FRESNO OXYGEN	FD -OXYGEN RENTALS		249.62
81308	03/09/23	Printed	GEIL ENTERPRISES INC	JANITORIAL SERVICES FEBRUARY 2023		4,686.00
81309	03/09/23	Printed	CYNTHIA GOMEZ	PD -911 CALNENA CONFERENCE MEALS & MILEAGE		698.75
81310	03/09/23	Printed	DAVID GRILIONE	AMBULANCE OVERPAYMENT REIMB		145.99
81311	03/09/23	Printed	HEALTHEDGE ADMINISTRATORS INC.	HR -DENTAL CLAIMS 3/1/23		4,255.80
81312	03/09/23	Printed	HEALTHWISE SERVICES, LLC.	FD -MEDICAL WASTE SERVICE		173.75
81313	03/09/23	Printed	HENRY SCHEIN INC.	FD -MEDICAL SUPPLIES		1,962.17
81314	03/09/23	Printed	JESUS HERNANDEZ	ADMIN -REIMB FOR CONTRACTOR SERVICES FOR CABINET DOOR, PARTS & LABOR -CH BREAKROOM		150.00
81315	03/09/23	Printed	RAUL R HERRERA JR / ECN POLYGRAPH & INVESTIGATIONS	HR -POLYGRAPH SERVICES 2/8/23		1,000.00
81316	03/09/23	Printed	VANESSA M. HERRERA / VANESSA'S MOBILE NOTARY	FD -NOTARY SERVICES 3/3/23		105.00
81317	03/09/23	Printed	KIMBERLY HOUSTON	ART C -SHE KILLS MONSTERS PROP SUPLIES REIMB.		273.30
81318	03/09/23	Printed	IMAGETREND INC.	FD -EPCR SOFTWARE SEPTEMBER 2022 & JANUARY 2023		859.28
81319	03/09/23	Printed	INDUSTRIAL SAFETY LLC	PW -SAFETY GLASSES		217.35
81320	03/09/23	Printed	KEN KATZ,LCSW,CTS	PD -TRAUMA SUPPORT SERVICES		1,612.50
81321	03/09/23	Printed	KINGS INDUSTRIAL OCCUPATION	HR -PRE EMPLOYMENT PHYSICALS		95.00
81322	03/09/23	Printed	KINGSBURG FOOD MART	BLDG -PERMIT OVERPAYMENT REIMB		200.00
81323	03/09/23	Printed	RUSSELL A KULOW / KULOW BROTHEF	PD -TRAFFIC CITATION BOOKS		1,252.47
81324	03/09/23	Printed	LEAGUE OF CALIFORNIA CITIES	ADMIN -ANNUAL MEMBERSHIP DUES		235.93
81325	03/09/23	Printed	LIFE-ASSIST INC.	FD -MEDICAL SUPPLIES		392.70
81326	03/09/23	Printed	TINA MALDONADO	PD -PUBLIC RECORDS ACT TRAINING MEALS & MILEAGE	R	280.00
81327	03/09/23	Printed	MEDLINE INDUSTRIES, INC.	FD -MEDICAL SUPPLIES		1,169.61
81328	03/09/23	Printed	METRO UNIFORM	PD -REVOLVING ACCT	R	141.83
81329	03/09/23	Printed	ANNA MULDERRIG / PANNA CHARTERS	SENIOR C -TRIP TO BLACK OAK CASINO		1,170.00
81330	03/09/23	Printed	ODELL PLANNING & RESEARCH, INC	PLANNING -SELMA GROVE EIR ADDENDUM PLANNING SERVICES	R	1,673.10
81331	03/09/23	Printed	ODP BUSINESS SOLUTIONS LLC	ADMIN -OFFICE SUPPLIES		225.09
81332	03/09/23	Printed	OOSOSHARP, LLC / SHARP	FD -AMBULANCE BILLING FEBRUARY 2023		8,892.73
81333	03/09/23	Printed	CHRISTOPHER ORTIZ-BELCHER	ART C -SHE KILLS MONSTERS DIRECTOR & PROPERTIES MASTER		200.00
81334	03/09/23	Printed	PG&E	UTILITIES -FEBRUARY 2023		221.14
81335	03/09/23	Printed	PG&E	UTILITIES -FEBRUARY 2023		32,481.10
81336	03/09/23	Printed	PG&E	UTILITIES -FEBRUARY 2023		18,054.13
81337	03/09/23	Printed	PG&E	UTILITIES -FEBRUARY 2023		373.40
81338	03/09/23	Printed	PITNEY BOWES BANK INC	ADMIN -POSTAGE REFILL FOR CH		936.37
81339	03/09/23	Printed	PITNEY BOWES GLOBAL FINANCIAL	ADMIN -POSTAGE MACHINE LEASE FOR CH 3/16/23-6/15/23		492.12
81340	03/09/23	Printed	QUAD KNOPF, INC.	PLANNING SERVICES 1/8-2/4/23	PARTIAL R	32,974.02
81341	03/09/23	Printed	GERALD REESER	FD -GYM MEMBERSHIP REIMBURSEMENT		200.00
81342	03/09/23	Printed	REXEL USA, INC.	FIN -CVTC SUPPLIES	R	8,737.24
81343	03/09/23	Printed	ANDREW RICO	FD -PARAMEDIC CLASS REIMB		2,000.00
81344	03/09/23	Printed	RINCON CONSULTANTS, INC.	PLANNING -ZONING ORDINANCE UPDATE		5,244.00
81345	03/09/23	Printed	DANIEL ANTHONY RIVAS	FD -TRAINING & TRAVEL REIMB FOR REGISTRATION/LODGING REIMB.		599.78
81346	03/09/23	Printed	ALBERT PEREZ RODRIGUEZ / 4 SEASON LAWN SERVICE	BLDG -CLEAN UP AT CATTLEMANS PROPERTY		200.00
81347	03/09/23	Printed	SAN JOAQUIN VALLEY AIR POLLUTION CONTROL DIST	PW -FILING FEE FOR PERMIT TO OPERATE GENERATOR AT SENIOR C		87.00

CHECK REGISTER REPORT

CHECK NUMBER	CHECK DATE	STATUS	VENDOR NAME	CHECK DESCRIPTION	CATEGORY	AMOUNT
81348	03/09/23	Printed	SANTA MARIA CALIFORNIA NEWS	PLANNING -PH NOTICE		183.13
81349	03/09/23	Printed	SCOTT'S PPE RECON, INC.	FD -DETERGENT		232.52
81350	03/09/23	Printed	CHARLES STALIE	SENIOR C -TRIP CANCELLATION REIMB.		20.00
81351	03/09/23	Printed	STATEWIDE TRAFFIC SAFETY AND	PW -SHEETING/BRITELINE TAPE/OVERLAY FOR ST SIGNS		3,091.23
81352	03/09/23	Printed	STEAM CLEANERS, INC.	FD -REPAIRS ON PORTABLE PRESSURE WASHER		141.51
81353	03/09/23	Printed	STERICYCLE, INC.	PD -STERI SAFE OSHA COMPLIANCE		189.28
81354	03/09/23	Printed	STRYKER SALES CORPORATION	FD -LIFEPAK		1,637.10
81355	03/09/23	Printed	TEC GROUP INC.	HUMAN RESOURCES TECHNICIAN 2/19/23		1,297.14
81356	03/09/23	Printed	THOMAS J O'LAUGHLIN MD INC.	FD -MEDICAL DIRECTOR APRIL 2023		500.00
81357	03/09/23	Printed	TYLER TECHNOLOGIES, INC.	FIN -ANNUAL MAINTENANCE AGREEMENT		6,022.77
81358	03/09/23	Printed	U.S. BANK CORPORATE PMT SYSTEM	CALCARD CHARGES 1/24-2/22/23	PARTIAL R	81,881.44
81359	03/09/23	Printed	U.S. BANK EQUIPMENT FINANCE	FIN -COPY MACHINE LEASE MARCH 2023		2,006.43
81360	03/09/23	Printed	VERIZON	FD -VEHICLE TRACKING FEBRUARY 2023		94.75
81361	03/09/23	Printed	VERIZON WIRELESS	AIRCARDS 1/19/23-2/18/23		994.86
81362	03/09/23	Printed	WASTE MANAGEMENT-USA WASTE	FIN -GARBAGE FEBRUARY 2023		135,437.68
81363	03/09/23	Printed	WILLDAN ENGINEERING	BLDG -INSPECTOR SERVICES THROUGH 1/27/23		2,655.00
81364	03/09/23	Void		Void Check		0.00
81365	03/09/23	Void		Void Check		0.00
81366	03/09/23	Printed	YAMABE & HORN ENGINEERING, INC	ENGINEERING SERVICES -JANUARY 2023		99,815.88
81367	03/09/23	Printed	ROSALINDA ZAVALA	SENIOR C -TRIP CANCELLATION		30.00
					TOTAL	593,269.83

Grant: G PD State Appropriation: PDSA (457) Reimbursement: R

US BANK INVOICE FOR CALCARD CHARGES: 1/24/23-2/22/23

TRANSACTION

EMPLOYEE NAME	DATE	VENDOR NAME	DESCRIPTION OF PURCHASE	ACCOUNT NUMBER	AMOUNT
ALVIN DIAS	2/6/2023	TOM DUFFY COMPANY	PRIMER, SELF LEVELING CONCRETE - CH RENOVATIONS	404-0000-700.100.008	2,260.38
ALVIN DIAS	2/6/2023	TENNIS POINT	CRACK REPAIR SYSTEM - PICKLEBALL COURTS	100-5300-600.250.000	74.98
ALVIN DIAS	2/15/2023	KIMBALL MIDWEST	811 MARKING PAINT	210-5400-600.250.000	542.94
ALVIN DIAS	2/15/2023	KIMBALL MIDWEST	811 MARKING PAINT	210-5400-600.250.000	104.14
ALVIN DIAS	2/17/2023	PESTICIDE APPLICATORS PROFESSIONAL ASSOCIATION	2023 MEMBERSHIP RENEWAL	210-5400-610.900.000	50.00
AMY SMART	1/25/2023	AMAZON MARKETPLACE	RETURNED ITEMS	805-0000-226.200.000	(296.87)
AMY SMART	1/25/2023	AMAZON MARKETPLACE	RETURNED ITEMS	805-0000-226.200.000	(28.19)
AMY SMART	2/15/2023	LEGENDS TAP HOUSE	STAFF MEETING	100-4100-610.920.000	57.87
ANDREW GUZMAN	1/23/2023	PETCO	DOG FOOD	100-2200-600.250.000	110.60
ANTHONY RIVAS	1/21/2023	EXXON MOBILE	FUEL FOR PREVENTION CLASS	701-9200-600.257.000	75.74
ANTHONY RIVAS	2/1/2023	PLAYAS DE ROSARITO	FOOD FOR FUNERAL MEETING	100-2525-600.250.000	138.62
CALEB GARCIA	1/24/2023	CHEVRON	FUEL - ACT	269-2100-600.257.000	77.72
CALEB GARCIA	1/27/2023	SELMA STATION	FUEL - ACT	269-2100-600.257.000	79.56
CALEB GARCIA	2/1/2023	SHELL OIL	FUEL - ACT	269-2100-600.257.000	54.72
CALEB GARCIA	2/2/2023	CHEVRON	FUEL - ACT	269-2100-600.257.000	59.66
CALEB GARCIA	2/7/2023	BOB'S VILLA MART	FUEL - ACT	269-2100-600.257.000	65.46
CALEB GARCIA	2/10/2023	CLOVIS MART	FUEL - ACT	269-2100-600.257.000	58.99
CALEB GARCIA	2/16/2023	CHEVRON	FUEL - ACT	269-2100-600.257.000	89.25
CASSY L FAIN	11/17/2022	CALIFORNIA PEACE OFFICER	FRAUD - CREDIT - RESOLVED	100-2100-610.910.000	(250.00)
CASSY L FAIN	1/17/2023	EB CENTRAL CALIFORNIA	FRAUD - CREDIT - RESOLVED	800-0000-121.000.000	(23.18)
CASSY L FAIN	2/14/2023	METRO UNIFORM & ACCESSORY	EQUIPMENT	100-2200-600.250.000	204.40
CITY OF SELMA FIRE QRT MST	1/22/2023	THE HOME DEPOT	PPE DEACON	100-2525-600.250.000	68.13
CITY OF SELMA FIRE QRT MST	1/25/2023	UNIQUELY YOURS INC.	E111 HOSE COVERS	100-2525-600.250.000	25.00
CITY OF SELMA FIRE QRT MST	1/27/2023	DTX TINT	T110 WINDOW TINT	100-2525-600.250.000	282.00
CITY OF SELMA FIRE QRT MST	1/30/2023	AMAZON	ST. 1 GATE SCREEN	100-2525-600.250.000	37.96
CITY OF SELMA FIRE QRT MST	1/30/2023	EBAY	RIP & RUN PRINTERS	100-2525-600.350.000	372.59
CITY OF SELMA FIRE QRT MST	1/30/2023	UBIQUITI INC.	FIREWALL FOR RIP & RUNS	111-2500-600.250.000	832.40
CITY OF SELMA FIRE QRT MST	1/30/2023	AMAZON	ST. 1 GATE SCREEN	100-2525-600.250.000	43.37
CITY OF SELMA FIRE QRT MST	1/31/2023	AMAZON	RIP & RUN PAPER	100-2525-600.250.000	65.07
CITY OF SELMA FIRE QRT MST	2/10/2023	THE HOME DEPOT	ST. 1 DISHWASHER	111-2500-600.250.000	757.16
CITY OF SELMA SNG RES 1	2/11/2023	FOOD 4 LESS SELMA	STATION CLEANING SUPPLIES	100-2525-600.250.000	80.03
CITY OF SELMA STATION 1	1/24/2023	WAL-MART	WATER	100-2525-600.250.000	51.52
CITY OF SELMA STATION 1	1/24/2023	THE HOME DEPOT	MOPS & DRAINIO	100-2525-600.250.000	79.41
CITY OF SELMA STATION 1	1/28/2023	MIRROR FINISH	CAR WASH SOAP	100-2525-600.250.000	76.15
CITY OF SELMA STATION 1	2/1/2023	WAL-MART	MOUSE TRAPS	100-2525-600.250.000	14.97
CITY OF SELMA STATION 1	2/4/2023	NAPA AUTO PARTS	PRE MIX FUEL	100-2525-600.250.000	26.01
CITY OF SELMA STATION 1	2/8/2023	NELSONS ACE HARDWARE	SLIMPLUG	100-2525-600.250.000	19.51
CITY OF SELMA STATION 1	2/8/2023	THE HOME DEPOT	SHELF & ANCHOR	100-2525-600.250.000	38.40
CITY OF SELMA STATION 1	2/8/2023	THE HOME DEPOT	SURGE PROTECTOR	100-2525-600.250.000	109.56
CITY OF SELMA STATION 1	2/10/2023	NELSONS ACE HARDWARE	ADD A TEE	100-2525-600.250.000	13.01
CITY OF SELMA STATION 1	2/20/2023	NELSONS ACE HARDWARE	BARRICADE TAPE	100-2525-600.250.000	60.70
CITY OF SELMA STATION 2	2/8/2023	THE HOME DEPOT	TRASH BAGS	100-2525-600.250.000	21.66
CITY OF SELMA STATION 2	2/9/2023	AMAZON	HOSE BED STRAPS	100-2525-600.250.000	138.80
CITY OF SELMA STATION 2	2/16/2023	SALS MEXICAN	LUNCH FOR COVER CREW- FUNERAL	100-2525-600.250.000	94.37
CITY OF SELMA TRAINING DIVISION	1/23/2023	ROGUE	STATION BIKE FOR STATION 2	100-2525-600.250.000	758.25
CITY OF SELMA TRAINING DIVISION	1/24/2023	EB CENTRAL CALIFORNIA	PEER SUPPORT TRAINING	295-2525-610.915.000	23.18
CITY OF SELMA TRAINING DIVISION	1/25/2023	MERCEDES BENZ OF FRESNO	PARTS FOR AMBULANCE	701-9200-600.256.000	242.66
CITY OF SELMA TRAINING DIVISION	1/26/2023	MERCEDES BENZ OF FRESNO	PARTS FOR AMBULANCE	701-9200-600.256.000	977.04
CITY OF SELMA TRAINING DIVISION	2/1/2023	BEST UNIFORMS	BADGES FOR CLASS A	100-2525-600.250.000	27.09
CITY OF SELMA TRAINING DIVISION	2/9/2023	JORGENSEN AND SONS	GAS DETECTOR CALIBRATION	100-2525-600.375.000	77.79
CITY OF SELMA TRAINING DIVISION	2/10/2023	PAYPAL CAL TRAINING	TRAINING SYMPOSIUM	295-2525-610.915.000	716.00
CITY OF SELMA TRAINING DIVISION	2/10/2023	PAYPAL CAL TRAINING	TRAINING SYMPOSIUM	295-2525-610.915.000	537.00
CITY OF SELMA TRAINING DIVISION	2/10/2023	ELITE COMMAND TRAINING	TRAINING CLASS	295-2525-610.915.000	700.00

US BANK INVOICE FOR CALCARD CHARGES: 1/24/23-2/22/23

EMPLOYEE NAME	DATE	VENDOR NAME	DESCRIPTION OF PURCHASE	ACCOUNT NUMBER	AMOUNT
CITY OF SELMA TRAINING DIVISION	2/10/2023	ELITE COMMAND TRAINING	TRAINING CLASS	295-2525-610.915.000	700.00
CITY OF SELMA TRAINING DIVISION	2/13/2023	THE HOME DEPOT	PARTS FOR TRAINING PROP	295-2525-610.915.000	102.95
CITY OF SELMA TRAINING DIVISION	2/16/2023	CITY OF FRESNO	PARKING FEE FOR FUNERAL	100-2525-600.250.000	3.39
CITY OF SELMA TRAINING DIVISION	2/16/2023	CITY OF FRESNO	PARKING FEE FOR FUNERAL	100-2525-600.250.000	3.39
EMS DIVISION 550	1/27/2023	76 DBA X-PRESS FOOD	FUEL	701-9200-600.257.000	85.60
EMS DIVISION 550	2/2/2023	NAVA BROTHERS AUTO DETAIL	VEHICLE SUPPLIES	600-2600-600.250.000	10.50
EMS DIVISION 550	2/18/2023	MIRROR FINISH POLISH	VEHICLE SUPPLIES	600-2600-600.250.000	42.96
EMS DIVISION 550	2/18/2023	THE HOME DEPOT	STATION SUPPLIES	600-2600-600.250.000	13.00
EMS DIVISION 550	2/20/2023	THE HOME DEPOT	STATION SUPPLIES	600-2600-600.250.000	19.28
EMS DIVISION 551	1/26/2023	UNIQUELY YOURS INC.	EMS EQUIPMENT	600-2600-600.250.000	70.00
EMS DIVISION 551	1/27/2023	CHEVRON	FUEL	701-9200-600.257.000	90.95
EMS DIVISION 552	2/14/2023	WAL-MART	STATION SUPPLIES - WATER	600-2600-600.250.000	36.80
EMS DIVISION 553	2/1/2023	CHEVRON	FUEL	701-9200-600.257.000	100.78
EMS DIVISION 553	2/15/2023	GRAPEVINE FOOD MART	FUEL	701-9200-600.257.000	114.00
FABIAN URESTI	1/31/2023	AMAZON	EMS SUPPLIES	600-2600-600.250.000	130.10
FABIAN URESTI	2/6/2023	WALMART.COM	OFFICE SUPPLIES	100-1600-600.100.000	13.47
FABIAN URESTI	2/7/2023	WALMART.COM	OFFICE SUPPLIES	100-1600-600.100.000	48.62
FERNANDO MORAN	1/26/2023	FAHRNEY FORD	OIL/FILTER CHANGE/TIRE ROTATION-UNIT #1006	701-9200-600.256.000	89.95
FERNANDO MORAN	1/26/2023	HOME DEPOT	PLIERS/WRENCH	100-5300-600.305.000	64.82
FERNANDO MORAN	1/26/2023	HOME DEPOT	AAA BATTERIES	100-5300-600.250.000	10.87
FERNANDO MORAN	2/1/2023	NELSON'S ACE HARDWARE	TIE TAPE STRETCH/CUT KEY	100-5300-600.250.000	21.43
FERNANDO MORAN	2/1/2023	HOME DEPOT	EXTENSION BAR DRIVES	100-5300-600.305.000	14.25
FERNANDO MORAN	2/6/2023	HOME DEPOT	PRIMER - SHAFER PARK RESTROOMS	456-4100-700.100.000	108.89
FERNANDO MORAN	2/8/2023	NELSON'S ACE HARDWARE	DEWALT 1/2' DRILL-PARKS	100-5300-600.305.000	47.01
FERNANDO MORAN	2/8/2023	NELSON'S ACE HARDWARE	DEWALT 1/2' DRILL-STREETS	210-5400-600.305.000	47.00
FERNANDO MORAN	2/8/2023	NELSON'S ACE HARDWARE	DEWALT 1/2' DRILL-BLDGS	702-9300-600.305.000	47.00
FERNANDO MORAN	2/9/2023	HOME DEPOT	ROUNDUP/9V BATTERIES	100-5300-600.250.000	318.63
FERNANDO MORAN	2/13/2023	NELSON'S ACE HARDWARE	P95 RESPIRATOR	100-5300-600.250.000	21.15
FERNANDO MORAN	2/13/2023	NELSON'S ACE HARDWARE	P95 RESPIRATOR	100-5300-600.305.000	21.14
FERNANDO MORAN	2/13/2023	HOME DEPOT	MORTAR/CHISEL/5 GALLON BUCKETS-SHAFER PARK RESTROOMS	456-4100-700.100.000	96.39
FERNANDO MORAN	2/13/2023	HOME DEPOT	EXTENSION CORDS	100-5300-600.305.000	78.51
FERNANDO MORAN	2/13/2023	HOME DEPOT	SAFETY GLASSES	100-5300-900.250.000	24.92
FERNANDO MORAN	2/15/2023	NELSON'S ACE HARDWARE	ROUND UP-PARKS	100-5300-600.250.000	65.00
FERNANDO MORAN	2/15/2023	NELSON'S ACE HARDWARE	ROUND UP-STREETS	210-5400-600.250.000	64.99
FERNANDO MORAN	2/15/2023	NELSON'S ACE HARDWARE	METAL CUTOFFS/LP TANKS-SHAFER PARK RESTROOMS	456-4100-700.100.000	144.06
FERNANDO MORAN	2/15/2023	HOME DEPOT	GRENCOR MORTAR - CREDIT	456-4100-700.100.000	(9.74)
FERNANDO MORAN	2/19/2023	AMAZON	PLUMBING SNAKE	702-9300-600.250.000	31.44
FERNANDO MORAN	2/21/2023	NELSON'S ACE HARDWARE	PLASTER/DRYWALL/SANDER/PAINT-SHAFER PARK RESTROOMS	456-4100-700.100.000	342.25
FERNANDO MORAN	01/23/2023	ROYCE ROLLS RINGER COMPANY	STP-3 SLANTED THREE ROLL TOILET PAPER DISPENSERS - SHAFER PARK RESTROOMS	456-4100-700.100.000	217.84
FERNANDO SANTILLAN	1/26/2023	FUGAZZIS	CITY MANAGER LUNCHEON	100-1300-610.920.000	26.44
FERNANDO SANTILLAN	2/6/2023	FRESNO BEE	NEWSPAPER SUBSCRIPTION	100-1300-600.250.000	1.00
FERNANDO SANTILLAN	2/16/2023	NESPRESSO	CITY HALL COFFEE	100-1300-600.250.000	94.10
FERNANDO SANTILLAN	2/16/2023	G'S RISTORANTE	HR MANAGER PANELIST LUNCHEON	100-1300-610.920.000	231.94
FERNANDO SANTILLAN	2/16/2023	LEGENDS TAP HOUSE	CITY HALL DINNER	100-1300-610.920.000	655.75
FERNANDO SANTILLAN	2/20/2023	THE TOLL ROADS OF OC	CITY MANAGER CONFERENCE - TRAVEL TOLL	100-1300-610.920.000	18.00
FERNANDO SANTILLAN	2/21/2023	LINKEDIN	MONTHLY SUBSCRIPTION	100-1300-600.250.000	139.99
FINANCE DEPARTMENT	1/31/2023	NELSONS ACE HARDWARE	CODE ENFORCEMENT - DUCT TAPE	100-3200-600.250.000	107.23
FINANCE DEPARTMENT	1/31/2023	THE HOME DEPOT	CODE ENFORCEMENT - SUPPLIES	100-3200-600.250.000	208.04
FINANCE DEPARTMENT	2/1/2023	BNP MEDIA	ENGINEERING NEWS RECORD REFUND	100-1300-610.900.000	(41.99)
GEORGE SIPIN	1/23/2023	O'REILLY	RELAYS - STOCK	603-5500-600.256.000	131.25
GEORGE SIPIN	1/23/2023	VULCAN'S WELDING & FABRICATION	REMOVE/INSTALL CAT CONVERTER-RT#147	603-5500-600.400.000	475.00
GEORGE SIPIN	1/24/2023	WALMART	KITCHEN & JANITORIAL SUPPLIES	603-5500-600.250.000	171.62

US BANK INVOICE FOR CALCARD CHARGES: 1/24/23-2/22/23

EMPLOYEE NAME	TRANSACTION DATE	VENDOR NAME	DESCRIPTION OF PURCHASE	ACCOUNT NUMBER	AMOUNT
GEORGE SIPIN	1/24/2023	NELSON'S ACE HARDWARE	CUTOFF WHEELS-STOCK	603-5500-600.250.000	17.54
GEORGE SIPIN	1/25/2023	VULCAN'S WELDING & FABRICATION	REPAIRED BRACKETS FOR BUMPER & BIKE RACK	603-5500-600.400.000	120.00
GEORGE SIPIN	1/25/2023	WALMART	TRASH BAGS FOR SHOP	603-5500-600.250.000	39.31
GEORGE SIPIN	1/25/2023	KINGSBURG SINCLAIR	PROPANE FOR SHOP HEATERS	603-5500-600.250.000	381.34
GEORGE SIPIN	1/26/2023	JORGENSEN COMPANY	ANNUAL FIRE EXTINGUISHER MAINT	603-5500-600.400.000	957.35
GEORGE SIPIN	1/26/2023	BLACKSTONE CHEVROLET	SWITCH - STOCK	603-5500-600.256.000	34.87
GEORGE SIPIN	1/30/2023	BLACKSTONE CHEVROLET	SENSORS - STOCK	603-5500-600.256.000	386.18
GEORGE SIPIN	1/30/2023	NAPA AUTO PARTS	AIR HOSE REELS & FITTINGS	603-5500-600.256.000	204.32
GEORGE SIPIN	1/31/2023	O'REILLY	COOL TEMP SENSORS/AIR REELS-STOCK	603-5500-600.256.000	334.85
GEORGE SIPIN	1/31/2023	ARMANDO'S SMOG	SMOG - RT#155	603-5500-600.400.000	80.00
GEORGE SIPIN	1/31/2023	ARMANDO'S SMOG	SMOG - RT#187	603-5500-600.400.000	80.00
GEORGE SIPIN	1/31/2023	NAPA AUTO PARTS	ZILLA REEL-CREDIT	603-5500-600.256.000	(188.52)
GEORGE SIPIN	1/31/2023	BLACKSTONE CHEVROLET	SENSOR - STOCK	603-5500-600.256.000	132.10
GEORGE SIPIN	1/31/2023	BLACKSTONE CHEVROLET	BLOCK ASSEMBLY - STOCK	603-5500-600.256.000	182.58
GEORGE SIPIN	2/1/2023	PROTERRA	COOLANTS, OIL, VALVES-STOCK	603-5500-600.256.000	2,378.93
GEORGE SIPIN	2/1/2023	NAPA AUTO PARTS	ASSORTED FEM DISCONNECT-STOCK	603-5500-600.256.000	7.57
GEORGE SIPIN	2/1/2023	FAHRNEY FORD	O2 SENSORS -RT#200	603-5500-600.256.000	335.70
GEORGE SIPIN	2/2/2023	O'REILLY	COOL TEM SENSOR-CRDT	603-5500-600.256.000	(11.88)
GEORGE SIPIN	2/2/2023	ARMANDO'S SMOG	SMOG RT#1445	603-5500-600.400.000	80.00
GEORGE SIPIN	2/2/2023	NELSON'S ACE HARDWARE	SHOP KEYS	603-5500-600.250.000	12.97
GEORGE SIPIN	2/3/2023	LES SCHWAB TIRES	RESTOCK TIRES	603-5500-600.256.000	1,106.88
GEORGE SIPIN	2/6/2023	O'REILLY	FUEL INJECTORS-STOCK	603-5500-600.256.000	297.48
GEORGE SIPIN	2/6/2023	O'REILLY	IRIDIUM PLUGS -STOCK	603-5500-600.256.000	86.95
GEORGE SIPIN	2/6/2023	O'REILLY	MAF & THROTTLE POS SEN-STOCK	603-5500-600.256.000	110.32
GEORGE SIPIN	2/8/2023	O'REILLY	BATTERIES - STOCK	603-5500-600.256.000	484.04
GEORGE SIPIN	2/8/2023	WALMART	KITCHEN SUPPLIES	603-5500-600.250.000	20.49
GEORGE SIPIN	2/8/2023	DESIGN PACKAGING	TOILET SEAT COVER	603-5500-600.250.000	80.50
GEORGE SIPIN	2/8/2023	BLACKSTONE CHEVROLET	HEADLAMPS -STOCK	603-5500-600.256.000	(135.44)
GEORGE SIPIN	2/8/2023	BLACKSTONE CHEVROLET	HEADLAMPS -STOCK	603-5500-600.256.000	(135.44)
GEORGE SIPIN	2/9/2023	O'REILLY	BATTERIES/RELAYS-STOCK	603-5500-600.256.000	828.44
GEORGE SIPIN	2/9/2023	PROTERRA	THERMISTOR/AIR COMPRESSOR-STOCK	603-5500-600.256.000	58.31
GEORGE SIPIN	2/10/2023	BLACKSTONE CHEVROLET	COOLANT TEMP CONNECTOR-STOCK	603-5500-600.256.000	59.40
GEORGE SIPIN	2/13/2023	SECURE STORAGE OF SELMA	STORAGE FOR FCRTA EQUIPMENT 4/23-10/23	603-5500-600.400.000	2,555.00
GEORGE SIPIN	2/13/2023	LES SCHWAB TIRES	REPAIR & REPLACE R/F BLOWOUT - RT#187	603-5500-600.457.000	1,167.94
GEORGE SIPIN	2/13/2023	LES SCHWAB TIRES	RESTOCK TIRES	603-5500-600.256.000	276.72
GEORGE SIPIN	2/13/2023	FRONTIER FASTENER	BITS, LUGS, MISC.	603-5500-600.256.000	131.61
GEORGE SIPIN	2/13/2023	BLACKSTONE CHEVROLET	COOLANT TEMP SENSORS-STOCK	603-5500-600.256.000	118.79
GEORGE SIPIN	2/14/2023	HOME DEPOT	SHOP & DETAILING SUPPLIES	603-5500-600.250.000	149.05
GEORGE SIPIN	2/15/2023	WALMART	CHARGING CORDS FOR TABLETS	603-5500-600.250.000	85.84
GEORGE SIPIN	2/15/2023	BLACKSTONE CHEVROLET	MODULES, CONNECTOR, SENSORS - STOCK	603-5500-600.256.000	1,314.76
GEORGE SIPIN	2/15/2023	HOME DEPOT	CAULKING GUN	603-5500-600.250.000	4.64
GEORGE SIPIN	2/16/2023	ROMITA AUTO SERVICE	REPLACE FUSE BLOCK-RT#161	603-5500-600.400.000	664.62
GEORGE SIPIN	2/17/2023	BLACKSTONE CHEVROLET	COOLANT TEMP SENSOR-STOCK	603-5500-600.256.000	132.10
GEORGE SIPIN	2/17/2023	BLACKSTONE CHEVROLET	CORE RETURN	603-5500-600.256.000	(135.44)
GEORGE SIPIN	2/17/2023	BLACKSTONE CHEVROLET	CORE RETURN	603-5500-600.256.000	(135.44)
JACOB DEL CID	1/23/2023	HOMEDEPOT.COM	CVTC SUPPLY ORDER #WP57474910	274-1600-600.250.000	66.54
JACOB DEL CID	1/27/2023	USPS SELMA CA	MAILING HR DOCUMENTS	100-1400-600.120.000	6.04
JACOB DEL CID	2/3/2023	HYATT CENTRIC SACRAMENTO	CSMFO CONFERENCE TRAVEL	100-1600-610.920.000	615.16
JACOB DEL CID	2/3/2023	ARCO	CSMFO CONFERENCE TRAVEL	100-1600-610.920.000	33.52
JACOB DEL CID	2/7/2023	HOMEDEPOT.COM	CVTC SUPPLY ORDER # WP58990462	274-1600-600.250.000	1,757.86
JACOB DEL CID	2/8/2023	HOMEDEPOT.COM	CVTC SUPPLY ORDER # WP58990462	274-1600-600.250.000	128.54
JACOB DEL CID	2/8/2023	HOMEDEPOT.COM	CVTC SUPPLY ORDER # WP58990462	274-1600-600.250.000	129.78

US BANK INVOICE FOR CALCARD CHARGES: 1/24/23-2/22/23

EMPLOYEE NAME	DATE	VENDOR NAME	DESCRIPTION OF PURCHASE	ACCOUNT NUMBER	AMOUNT
JACOB DEL CID	2/10/2023	THE HOME DEPOT SELMA	CVTC SUPPLY STORE ORDER	274-1600-600.250.000	162.63
JACOB DEL CID	2/10/2023	THE HOME DEPOT SELMA	CVTC SUPPLY STORE ORDER	274-1600-600.250.000	367.73
JACOB DEL CID	2/8/2023	HOMEDEPOT.COM	CVTC SUPPLY ORDER # WP58990462	274-1600-600.250.000	75.90
JASMIN BAINS	1/26/2023	CSMFO	CSMFO MEMBERSHIP FEE	100-1600-610.900.000	125.00
JASMIN BAINS	1/27/2023	GRAMMARLY	SUBSCRIPTION	100-1600-600.470.000	144.00
JASMIN BAINS	1/31/2023	TASTE OF INDIA	CSMFO TRAVEL MEAL	100-1600-610.920.000	13.32
JASMIN BAINS	2/2/2023	CALI PIZZA KITCHEN	CSMFO TRAVEL MEAL	100-1600-610.920.000	35.85
JASMIN BAINS	2/3/2023	LINKEDIN	SUBSCRIPTION	100-1600-610.900.000	169.99
JASMIN BAINS	2/3/2023	HYATT REGENCY SACRAMENTO	CSMFO CONFERENCE HOTEL	100-1600-610.920.000	8.00
JASMIN BAINS	2/3/2023	HYATT REGENCY SACRAMENTO	CSMFO CONFERENCE HOTEL - A. GONZALEZ	100-1600-610.920.000	1,488.54
JASMIN BAINS	2/3/2023	HYATT REGENCY SACRAMENTO	CSMFO CONFERENCE HOTEL	100-1600-610.920.000	689.66
JASMIN BAINS	2/6/2023	STARBUCKS	CSMFO TRAVEL MEAL	100-1600-610.920.000	36.55
JASMIN BAINS	2/10/2023	HOMEDEPOT.COM	CVTC SUPPLY ORDER #WE12757935 RETURN	274-1600-600.250.000	(432.82)
JASMIN BAINS	2/21/2023	DROPBOX	STORAGE SUBSCRIPTION	100-1600-600.470.000	119.88
JESUS HERNANDEZ	1/24/2023	HOME DEPOT	6PC PIN SET/3PC CHISEL SET-TOOLS	210-5400-600.305.000	32.98
JESUS HERNANDEZ	1/24/2023	HOME DEPOT	PROPANE TANK EXCHANGE-STREETS	210-5400-600.250.000	21.99
JESUS HERNANDEZ	1/24/2023	HOME DEPOT	TARP/PVC PIPES/FAUCET SUPPLY LINE-CITY YARD	702-9300-600.370.000	162.65
JESUS HERNANDEZ	1/24/2023	HOME DEPOT	SCREWDRIVER SET/PLIERS/CLAMPS-TOOLS	702-9300-600.305.000	237.98
JESUS HERNANDEZ	1/25/2023	AMAZON	MAXIMUM OCCUPANCY SIGN-SENIOR CENTER	702-9300-600.250.000	17.30
JESUS HERNANDEZ	1/25/2023	NELSON'S ACE HARDWARE	CUT KEYS-BLDGS	702-9300-600.250.000	5.84
JESUS HERNANDEZ	1/26/2023	HOME DEPOT	ELECTRICIAN TOOL BAG-STREETS	210-5400-600.305.000	54.22
JESUS HERNANDEZ	1/31/2023	EBAY	SCHLAGE L9010 DOOR MORTISE LOCK-PD REPAIRS	702-9300-600.370.000	92.15
JESUS HERNANDEZ	1/31/2023	HOME DEPOT	TOOL BAGS -BLDGS	702-9300-600.305.000	54.14
JESUS HERNANDEZ	1/31/2023	HOME DEPOT	LINERS/ROLLER TRAYS/ROLLERS-CITY HALL RENOVATIONS	404-0000-700.100.008	88.39
JESUS HERNANDEZ	1/31/2023	HOME DEPOT	SANDING DISCS-CITY HALL RENOVATIONS	404-0000-700.100.008	43.26
JESUS HERNANDEZ	1/31/2023	HOME DEPOT	FLOOR POLISHER RENTAL DEPOSIT-CITY HALL RENOVATIONS	404-0000-700.100.008	150.00
JESUS HERNANDEZ	2/1/2023	NELSON'S ACE HARDWARE	BRAD STEEL/ACRYLIC-CITY YARD REPAIRS	702-9300-600.370.000	186.53
JESUS HERNANDEZ	2/1/2023	NELSON'S ACE HARDWARE	RESPIRATORS/GALV NIPP-CITY HALL RENOVATIONS	404-0000-700.100.008	120.98
JESUS HERNANDEZ	2/1/2023	NELSON'S ACE HARDWARE	SCREW DRIVING BIT SETS -STREETS TOOLS	210-5400-600.305.000	19.99
JESUS HERNANDEZ	2/1/2023	NELSON'S ACE HARDWARE	CUT KEYS/HARDWARE-BLDGS	702-9300-600.370.000	36.36
JESUS HERNANDEZ	2/1/2023	HOME DEPOT	PRIMER/PAINT/LED BULBS-CITY HALL RENOVATIONS	404-0000-700.100.008	121.57
JESUS HERNANDEZ	2/1/2023	HOME DEPOT	VACUUM-CITY HALL	702-9300-600.305.000	150.66
JESUS HERNANDEZ	2/1/2023	HOME DEPOT	13 POCKET UTILITY POUCHES-BLDGS TOOLS	702-9300-600.305.000	60.37
JESUS HERNANDEZ	2/1/2023	HOME DEPOT	FLOORING COMPOUND-CITY HALL RENOVATIONS	404-0000-700.100.008	52.36
JESUS HERNANDEZ	2/1/2023	HOME DEPOT	SANDING DISCS-CITY HALL RENOVATIONS	404-0000-700.100.008	32.44
JESUS HERNANDEZ	2/2/2023	AMAZON	LOCKSET MORTISE CYLINDER-PD REPAIRS	702-9300-600.370.000	15.07
JESUS HERNANDEZ	2/2/2023	HOME DEPOT	13 POCKET UTILITY POUCH-STREETS TOOLS	210-5400-600.305.000	30.35
JESUS HERNANDEZ	2/2/2023	HOME DEPOT	FLOOR POLISHER RENTAL-CITY HALL RENOVATIONS	404-0000-700.100.008	79.66
JESUS HERNANDEZ	2/6/2023	NELSON'S ACE HARDWARE	BAR CLAMP-TOOLS (PD)	702-9300-600.305.000	60.72
JESUS HERNANDEZ	2/6/2023	HOME DEPOT	LED LIGHTS-CITY HALL RENOVATIONS(CRDT)	404-0000-700.100.008	(121.36)
JESUS HERNANDEZ	2/6/2023	HOME DEPOT	LED LIGHTS-CITY HALL RENOVATIONS	404-0000-700.100.008	121.36
JESUS HERNANDEZ	2/6/2023	HOME DEPOT	LEVELPRO SELF LEVELING UNDERLAYMENT-CITY HALL RENOVATIONS	404-0000-700.100.008	113.90
JESUS HERNANDEZ	2/8/2023	DESOTO SALES INC	50LB BAG SELF LEVELING CONCRETE-CITY HALL RENOVATIONS	404-0000-700.100.008	258.72
JESUS HERNANDEZ	2/8/2023	NELSON'S ACE HARDWARE	PRIMER/PAINT-CITY HALL RENOVATIONS	404-0000-700.100.008	256.70
JESUS HERNANDEZ	2/8/2023	NELSON'S ACE HARDWARE	ROOF CEMENT/HARDWARE-CITY YARD REPAIRS	702-9300-600.370.000	55.76
JESUS HERNANDEZ	2/13/2023	NELSON'S ACE HARDWARE	PAINT-CITY HALL RENOVATIONS	404-0000-700.100.008	206.59
JESUS HERNANDEZ	2/13/2023	NELSON'S ACE HARDWARE	SRAYSHIELDS/MARKERS-CITY HALL RENOVATIONS-TOOLS	404-0000-700.100.008	107.14
JESUS HERNANDEZ	2/14/2023	HOME DEPOT	DRILL BITS/OSCILLATING BLADE & TOOL-CITY HALL RENOVATIONS	404-0000-700.100.008	218.23
JESUS HERNANDEZ	2/15/2023	HOME DEPOT	BASE ADHESIVE/ADHESIVE APPLICATOR-CITY HALL RENOVATIONS	404-0000-700.100.008	139.28
JESUS HERNANDEZ	2/15/2023	HOME DEPOT	HIDEAWAY PLUNGER-PD	702-9300-600.250.000	23.72
JOHNNIE CERDA	1/31/2023	GALLS	PATROL DUTY EQUIPMENT	100-2200-600.250.000	157.41
JOHNNIE CERDA	2/9/2023	TACTICAL GEAR	PATROL DUTY EQUIPMENT	100-2200-600.250.000	701.14

US BANK INVOICE FOR CALCARD CHARGES: 1/24/23-2/22/23

TRANSACTION

EMPLOYEE NAME	DATE	VENDOR NAME	DESCRIPTION OF PURCHASE	ACCOUNT NUMBER	AMOUNT
JOHNNIE CERDA	2/11/2023	GALLS	PATROL DUTY EQUIPMENT	100-2200-600.250.000	48.62
LISBETH MARTINEZ	1/24/2023	CHALIO'S	SENIOR MEALS	230-4500-600.250.800	650.85
LISBETH MARTINEZ	1/25/2023	WALMART	CHROMECAST REIMBURSEMENT	805-0000-226.200.000	(32.52)
LISBETH MARTINEZ	1/25/2023	WALMART	SENIOR CENTER BREAKFAST/SNACKS	230-4500-600.250.800	276.18
LISBETH MARTINEZ	1/27/2023	AMAZON MARKETPLACE	SENIOR CENTER COFFEE BAR ITEMS	805-0000-226.200.000	70.44
LISBETH MARTINEZ	1/31/2023	SIERRA MARKET	BREAD FOR SENIOR CENTER	230-4500-600.250.800	29.44
LISBETH MARTINEZ	2/3/2023	AMAZON MARKETPLACE	COFFEE CUP HOLDER FOR SENIOR CENTER	805-0000-226.200.000	18.43
LISBETH MARTINEZ	2/10/2023	SIERRA MARKET	BREAD FOR SENIOR CENTER	230-4500-600.250.800	6.98
LISBETH MARTINEZ	2/13/2023	DOLLAR TREE	BALLOONS FOR SENIOR CENTER DANCE	805-0000-226.200.000	10.85
LISBETH MARTINEZ	2/13/2023	WALMART	SENIOR CENTER BREAKFAST/SNACKS	230-4500-600.250.800	446.78
LISBETH MARTINEZ	2/13/2023	FOOD 4 LESS SELMA	SODAS FOR SENIOR CENTER DANCE	805-0000-226.200.000	41.57
NESTOR GALVAN	1/23/2023	CAMACHO TIRES	ALIGNMENT & CAMBER KIT- UNIT 184	701-9200-600.255.000	195.00
NESTOR GALVAN	1/23/2023	CAMACHO TIRES	TIRE INSTALL & BALANCE- UNIT 199	701-9200-600.255.000	45.00
NESTOR GALVAN	1/23/2023	THE MOWERS EDGE	CARBURETOR	701-9200-600.256.000	271.26
NESTOR GALVAN	1/24/2023	TIFCO INDUSTRIES	THREADER LOCK GEL & THREAD SEALANT	701-9200-600.254.000	217.51
NESTOR GALVAN	1/24/2023	O'REILLY AUTO	16OZ STABILIZER	701-9200-600.254.000	11.38
NESTOR GALVAN	1/24/2023	FAST UNDERCAR	PARTS FOR UNIT 185	701-9200-600.256.000	1,302.74
NESTOR GALVAN	1/24/2023	QUINN PARTS	INSPECT & REPAIR WHEEL BEARINGS	701-9200-600.375.000	4,779.68
NESTOR GALVAN	1/24/2023	QUINN PARTS	REMOVE & INSTALL STICK CYLINDER	701-9200-600.375.000	2,714.85
NESTOR GALVAN	1/25/2023	O'REILLY AUTO	FLEET RUNNER & MICRO-V BELT- UNIT 552	701-9200-600.256.000	101.04
NESTOR GALVAN	1/25/2023	O'REILLY AUTO	LOCKING TOOL- SMALL TOOLS	701-9200-600.305.000	18.43
NESTOR GALVAN	1/26/2023	SELMA LES SCHWAB	TIRES / PARTS FOR UNIT 1402	701-9200-600.255.000	986.56
NESTOR GALVAN	1/26/2023	FAHRNEY BUICK GMC	OIL & FILTER WITH TIRE ROTATION- UNIT 729	701-9200-600.256.000	93.51
NESTOR GALVAN	1/27/2023	O'REILLY AUTO	OIL FILTER- SHOP PARTS	701-9200-600.256.000	114.42
NESTOR GALVAN	1/27/2023	O'REILLY AUTO	AIR FILTER-UNIT 550	701-9200-600.256.000	34.34
NESTOR GALVAN	1/27/2023	NELSONS ACE HARDWARE	AUTOCUT - UNIT 3209	701-9200-600.256.000	264.55
NESTOR GALVAN	1/30/2023	HI-LINE, INC.	TAPE, SCOTCH, & CHALKSHOT MARKING PEN- PARTS	701-9200-600.250.000	112.87
NESTOR GALVAN	1/30/2023	NELSONS ACE HARDWARE	52G DRUM- 2CYCLE FUEL	701-9200-600.257.000	1,198.64
NESTOR GALVAN	1/31/2023	O'REILLY AUTO	BRAKE ROTOR, HUB BOLTS, DISC PAD SET- UNIT 8560	701-9200-600.256.000	226.55
NESTOR GALVAN	1/31/2023	O'REILLY AUTO	AXLE O-RINGS- UNIT 8560	701-9200-600.256.000	8.92
NESTOR GALVAN	2/1/2023	FAST UNDERGROUND	ROTOR, POLICE PAD, STRUT- UNIT 8560 & UNIT196	701-9200-600.256.000	777.32
NESTOR GALVAN	2/1/2023	NELSONS ACE HARDWARE	CAR KEY	701-9200-600.250.000	27.06
NESTOR GALVAN	2/1/2023	CAMACHO TIRES	TIRE INSTALL & BALANCE- UNIT 196	701-9200-600.255.000	180.00
NESTOR GALVAN	2/1/2023	THE MOWERS EDGE	PULLEY IDLER- UNIT 3205	701-9200-600.256.000	281.82
NESTOR GALVAN	2/1/2023	SWANSON FAHRNEY FORD	FAN & PARTS FOR UNIT 187	701-9200-600.256.000	187.13
NESTOR GALVAN	2/2/2023	ASBURY ENVIRONMENTAL	OIL RECYCLING	701-9200-600.400.000	85.00
NESTOR GALVAN	2/2/2023	SELMA LES SCHWAB	TIRES FOR MANITOU- UNIT 1402	701-9200-600.255.000	1,930.04
NESTOR GALVAN	2/2/2023	ELBERT DISTRIBUTING	SHOP FLUIDS	701-9200-600.254.000	682.16
NESTOR GALVAN	2/2/2023	CAMACHO TIRES	TIRE INSTALL & BALANCE- UNIT 1001	701-9200-600.255.000	135.00
NESTOR GALVAN	2/2/2023	SWANSON FAHRNEY FORD	REPAIRS FOR UNIT 1004	701-9200-600.457.000	432.60
NESTOR GALVAN	2/2/2023	SWANSON FAHRNEY FORD	REPAIR & OIL CHANGE WITH TIRE ROTATION- UNIT 1001	701-9200-600.457.000	266.39
NESTOR GALVAN	2/3/2023	O'REILLY AUTO	CREDIT FOR RETURN OF PART	701-9200-600.256.000	(69.99)
NESTOR GALVAN	2/3/2023	O'REILLY AUTO	CANSTR SOL- UNIT 1005	701-9200-600.254.000	69.99
NESTOR GALVAN	2/3/2023	COLIN'S UPHOLSTERY	BUCKET SEAT, FABRIC & FOAM- UNIT 185	701-9200-600.400.000	1,249.50
NESTOR GALVAN	2/6/2023	SELMA LES SCHWAB	245/55R- 18 TIRES	701-9200-600.255.000	2,681.36
NESTOR GALVAN	2/6/2023	FAST UNDERCAR	PARTS FOR UNIT 184	701-9200-600.256.000	1,361.15
NESTOR GALVAN	2/7/2023	O'REILLY AUTO	VAPOR CAN VALVE - UNIT 1005	701-9200-600.254.000	35.02
NESTOR GALVAN	2/7/2023	O'REILLY AUTO	GLOVES - SHOP PARTS	701-9200-600.250.000	56.37
NESTOR GALVAN	2/8/2023	FAST UNDERCAR	RETURN OF PART	701-9200-600.256.000	(226.45)
NESTOR GALVAN	2/8/2023	O'REILLY AUTO	THERMOSTAT & OUTLET SEAL- UNIT 193	701-9200-600.256.000	7.22
NESTOR GALVAN	2/8/2023	O'REILLY AUTO	FILTERS FOR UNIT 1008	701-9200-600.256.000	48.11
NESTOR GALVAN	2/8/2023	SELMA LES SCHWAB	TIRES FOR POLICE CHARGER- UNIT 1008	701-9200-600.255.000	616.10

US BANK INVOICE FOR CALCARD CHARGES: 1/24/23-2/22/23

EMPLOYEE NAME	TRANSACTION DATE	VENDOR NAME	DESCRIPTION OF PURCHASE	ACCOUNT NUMBER	AMOUNT
NESTOR GALVAN	2/8/2023	SELMA LES SCHWAB	4 WHEEL ALIGNMENT- UNIT 1008	701-9200-600.255.000	180.21
NESTOR GALVAN	2/9/2023	O'REILLY AUTO	GASKET- UNIT 193	701-9200-600.256.000	5.76
NESTOR GALVAN	2/9/2023	NAPA AUTO PARTS	FLUIDS	701-9200-600.254.000	211.42
NESTOR GALVAN	2/9/2023	NAPA AUTO PARTS	THERMOSTAT HOUSING GASKET- UNIT 193	701-9200-600.256.000	6.69
NESTOR GALVAN	2/10/2023	CAMACHO TIRES	AMULET TIRES- UNIT 1318	701-9200-600.255.000	1,080.00
NESTOR GALVAN	2/13/2023	O'REILLY AUTO	CONNECTOR- UNIT 720	701-9200-600.256.000	17.35
NESTOR GALVAN	2/13/2023	O'REILLY AUTO	FOG CAPSULE- UNIT 720	701-9200-600.256.000	5.19
NESTOR GALVAN	2/13/2023	O'REILLY AUTO	OIL FILTER- SHOP PARTS	701-9200-600.256.000	76.28
NESTOR GALVAN	2/13/2023	O'REILLY AUTO	CONNECTOR- UNIT 720	701-9200-600.256.000	14.09
NESTOR GALVAN	2/13/2023	K AUDIO	RADIO REPAIR	701-9200-600.400.000	160.00
NESTOR GALVAN	2/13/2023	NAPA AUTO PARTS	THERMOSTAT GASKET	701-9200-600.256.000	(6.69)
NESTOR GALVAN	2/13/2023	NAPA AUTO PARTS	WATER OUTLET GASKET	701-9200-600.256.000	20.59
NESTOR GALVAN	2/14/2023	O'REILLY AUTO	BATTERY FOR UNIT 716	701-9200-600.256.000	190.34
NESTOR GALVAN	2/14/2023	CAMACHO TIRES	TIRE INSTALL & BALANCE- UNIT 1000	701-9200-600.255.000	45.00
NESTOR GALVAN	2/14/2023	CAMACHO TIRES	ALIGNMENT- UNIT 1000	701-9200-600.255.000	120.00
NESTOR GALVAN	2/14/2023	NAPA AUTO PARTS	TAPE- SHOP PARTS	701-9200-600.250.000	11.68
NESTOR GALVAN	2/15/2023	KIMBALL MIDWEST	PARTS FOR BLOWERS	701-9200-600.256.000	31.69
NESTOR GALVAN	2/15/2023	O'REILLY AUTO	BUTANE- SHOP PARTS	701-9200-600.250.000	15.16
NESTOR GALVAN	2/15/2023	NELSONS ACE HARDWARE	NIPPLE- SHOP PARTS	701-9200-600.250.000	6.43
NESTOR GALVAN	2/15/2023	NELSONS ACE HARDWARE	NIPPLE- SHOP PARTS	701-9200-600.250.000	6.43
NESTOR GALVAN	2/16/2023	NAPA AUTO PARTS	LOCK UNIT 716	701-9200-600.256.000	30.03
NESTOR GALVAN	2/17/2023	NAPA AUTO PARTS	SUPPORT PART FOR UNIT 716	701-9200-600.256.000	22.52
NESTOR GALVAN	2/17/2023	O'REILLY AUTO	OIL FILTER & OIL- UNIT 276	701-9200-600.254.000	46.95
NESTOR GALVAN	2/19/2023	AMAZON	LED LIGHTS & HEADLAMP- UNITS 1315 & 720	701-9200-600.256.000	63.19
NESTOR GALVAN	2/21/2023	TIFCO INDUSTRIES	TORQUE HOSE CLAMP	701-9200-600.256.000	202.86
NESTOR GALVAN	2/21/2023	TIFCO INDUSTRIES	ELECTRICAL TERMINAL, GLOVES & CHEMICAL	701-9200-600.250.000	612.59
NESTOR GALVAN	2/21/2023	CAMACHO TIRES	TIRES FOR WOOD CHIPPER	701-9200-600.255.000	610.00
NESTOR GALVAN	2/22/2023	LKQ INC	DIFFERENTIAL FOR UNIT 721	701-9200-600.256.000	1,716.62
NICOLETTE ANDERSEN	1/22/2023	GOODWILL INDUSTRIES	SHE KILLS MONSTERS PROPS/ COSTUMES	605-4300-656.540.047	6.04
NICOLETTE ANDERSEN	1/22/2023	AMVETS	SHE KILLS MONSTERS PROPS/ COSTUMES	605-4300-656.540.047	4.12
NICOLETTE ANDERSEN	1/27/2023	AMAZON	SHE KILLS MONSTERS - SUPPLIES	605-4300-656.540.047	185.04
NICOLETTE ANDERSEN	1/27/2023	SLACK	MARKETING PLATFORM MONTHLY FEE	605-4300-600.400.000	50.52
NICOLETTE ANDERSEN	1/27/2023	AMAZON	SHE KILLS ,MONSTERS- SUPPLIES	605-4300-656.540.047	30.45
NICOLETTE ANDERSEN	1/28/2023	AMAZON	SHE KILLS MONSTERS - SUPPLIES	605-4300-656.540.047	117.10
NICOLETTE ANDERSEN	1/28/2023	MADMAPPER	SHE KILLS MONSTERS - PROJECTION LICENSE	605-4300-656.540.047	49.52
NICOLETTE ANDERSEN	1/31/2023	AMAZON	SHE KILLS MONSTERS - SET SUPPLIES	605-4300-656.540.047	31.46
NICOLETTE ANDERSEN	1/31/2023	THE HOME DEPOT	SHE KILLS MONSTERS - SET SUPPLIES	605-4300-656.540.047	67.93
NICOLETTE ANDERSEN	2/1/2023	AMAZON	SHE KILLS MONSTERS - SET SUPPLIES	605-4300-656.540.047	79.69
NICOLETTE ANDERSEN	2/1/2023	AMAZON	SHE KILLS MONSTERS - SET SUPPLIES	605-4300-656.540.047	18.42
NICOLETTE ANDERSEN	2/1/2023	THE HOME DEPOT	SHE KILLS MONSTERS - SET SUPPLIES	605-4300-656.540.047	14.25
NICOLETTE ANDERSEN	2/3/2023	WALMART	SHE KILLS MONSTERS - SNACK BAR	605-4300-656.540.047	252.25
NICOLETTE ANDERSEN	2/3/2023	WALGREENS	SHE KILLS MONSTERS - SUPPLIES	605-4300-656.540.047	51.95
NICOLETTE ANDERSEN	2/6/2023	PAYPAL CLUTTER ART	FRESNO ANIME EXPO -SKM AD	605-4300-656.540.047	125.00
NICOLETTE ANDERSEN	2/6/2023	OPC CA DIR DOSH FE	ELEVATOR INSPECTION FEE	702-9300-600.400.000	250.00
NICOLETTE ANDERSEN	2/6/2023	OPC CA DIR DOSH FE	ELEVATOR INSPECTION FEE	702-9300-600.400.000	5.75
NICOLETTE ANDERSEN	2/7/2023	AMAZON	FOG MACHINE	100-4500-600.250.000	455.58
NICOLETTE ANDERSEN	2/10/2023	AMAZON PRIME	AMAZON PRIME MONTHLY FEE	605-4300-600.400.000	16.26
NICOLETTE ANDERSEN	2/10/2023	WALMART	SHE KILLS MONSTERS - SNACK BAR	605-4300-656.540.047	104.71
NICOLETTE ANDERSEN	2/10/2023	WALGREENS	SHE KILLS MONSTERS- SUPPLIES	605-4300-656.540.047	47.15
NICOLETTE ANDERSEN	2/11/2023	SAVEMART	SHE KILLS MONSTERS - SNACK BAR	605-4300-656.540.047	55.41
NICOLETTE ANDERSEN	2/15/2023	WALMART	SHE KILLS MONSTERS - SNACK BAR	605-4300-656.540.047	154.41
NICOLETTE ANDERSEN	2/16/2023	AMAZON	SHE KILLS MONSTERS - BATTERIES	605-4300-656.540.047	92.52

US BANK INVOICE FOR CALCARD CHARGES: 1/24/23-2/22/23

TRANSACTION

EMPLOYEE NAME	DATE	VENDOR NAME	DESCRIPTION OF PURCHASE	ACCOUNT NUMBER	AMOUNT
NICOLETTE ANDERSEN	2/16/2023	AMAZON	CITY OF SELMA - FINANCE	100-1600-600.100.000	27.01
NICOLETTE ANDERSEN	2/16/2023	LOOKING GLASS MEDIA	CINDERELLA MOVE THEATER AD	605-4300-656.540.048	525.00
NICOLETTE ANDERSEN	2/16/2023	NELSON ACE HARDWARE	SHE KILLS MONSTERS - BATTERIES	605-4300-656.540.047	29.26
NICOLETTE ANDERSEN	2/19/2023	LIQUOR LOCKER	SHE KILLS MONSTERS - BAR SALES	605-4300-656.540.047	18.46
NICOLETTE ANDERSEN	2/20/2023	AMAZON	CINDERELLA - PROPS / COSTUMES	605-4300-656.540.048	21.32
NICOLETTE ANDERSEN	2/20/2023	AMAZON	CINDERELLA - PROPS / COSTUMES	605-4300-656.540.048	9.75
NICOLETTE ANDERSEN	2/21/2023	AMAZON	CINDERELLA - PROPS / COSTUMES	605-4300-656.540.048	1,604.43
NICOLETTE ANDERSEN	2/22/2023	AMAZON	CINDERELLA - COSTUMES	605-4300-656.540.048	107.39
POLICE DEPARTMENT NO 1	1/25/2023	AMAZON	CREDIT FOR RETURN	100-2200-600.400.700	(58.73)
POLICE DEPARTMENT NO 1	1/30/2023	RESIDENCE INN-MARRIOT	TINA MALDONADO - HOTEL FOR TRAINING	100-2100-610.915.000	426.32
POLICE DEPARTMENT NO 1	1/31/2023	RESIDENCE INN-MARRIOT	CYNTHIA GOMEZ - HOTEL FOR TRAINING	100-2100-610.915.000	213.16
POLICE DEPARTMENT NO 1	2/13/2023	ALLARD'S, INC	FRAMES - CARRASCO GIFT	100-2100-600.400.000	376.98
POLICE DEPARTMENT NO 2	1/30/2023	METRO UNIFORM & ACCESSORY	UNIFORMS - JUAN MENDEZ CODE ENFORCEMENT	100-0000-123.010.000	187.90
POLICE DEPARTMENT NO 2	1/30/2023	METRO UNIFORM & ACCESSORY	UNIFORMS - LEONARD RAMIREZ CODE ENFORCEMENT	100-0000-123.010.000	285.82
POLICE DEPARTMENT NO 2	1/31/2023	PEAVY SUPPLIES	GUN BOXES - EVIDENCE SUPPLIES	100-2100-600.250.000	344.04
POLICE DEPARTMENT NO 2	2/7/2023	CHEVRON	FUEL FOR UNIT	701-9200-600.250.000	20.16
POLICE DEPARTMENT NO 2	2/7/2023	HOBBY-LOBBY	ART EASEL - OFFICE DISPLAY	100-2200-600.250.000	32.16
RENE GARZA	1/26/2023	AMAZON MARKETPLACE	ID PRINTER MACHINE - PER CHIEF	100-2200-600.250.000	975.18
RENE GARZA	1/27/2023	76 - GOLDEN HILL GAS STATION	FUEL	701-9200-600.257.000	57.60
RENE GARZA	2/7/2023	GULF OIL GAS STATION	FUEL	701-9200-600.257.000	59.13
RENE GARZA	2/15/2023	SELMA 76 GAS STATION	FUEL	701-9200-600.257.000	55.15
REYNA RIVERA	1/30/2023	CANVA	SUBSCRIPTION	100-1700-600.215.000	12.99
RICHARD FIGUEROA	2/6/2023	HOME DEPOT	SUPPLIES - GRAFFITI REMOVAL - CODE ENFORCEMENT	100-2100-600.250.000	313.50
RICHARD FIGUEROA	2/7/2023	USPS	AXON BODY CAMERA - RETURN ITEMS	100-2100-600.250.000	45.79
RICHARD FIGUEROA	2/9/2023	HOME DEPOT	SUPPLIES - GRAFFITI REMOVAL - CODE ENFORCEMENT	100-2100-600.250.000	203.85
RICHARD FIGUEROA	2/13/2023	METRO UNIFORM & ACCESSORY	BELT KEEPERS X 5 SETS	100-2100-600.250.000	113.50
ROBYN LEWIS	1/24/2023	AMAZON MARKETPLACE	SUPPLIES - WHITE NOISE MACHINES	100-2100-600.250.000	182.16
ROBYN LEWIS	2/12/2023	AMAZON MARKETPLACE	SUPPLIES - TAPE AND REDACTION PENS	100-2100-600.250.000	68.93
ROBYN LEWIS	2/13/2023	THE UPS STORE	SUBPOENA FOR RECORDS - MAILED	100-2100-600.120.000	13.61
ROBYN LEWIS	2/16/2023	PITNEY BOWES	POSTAGE METER INK	100-2100-600.250.000	117.02
ROBYN LEWIS	2/20/2023	AMAZON MARKETPLACE	SUPPLIES - PENS AND BINDERS	100-2100-600.250.000	75.07
ROBYN LEWIS	2/20/2023	AMAZON MARKETPLACE	SUPPLIES - WRITING PADS	100-2100-600.250.000	6.57
RUDOLFO ALCARAZ	1/23/2023	THE WOOD VENEER HUB	SOUND PROOFING PANELS	100-2100-600.400.000	271.17
RUDOLFO ALCARAZ	2/9/2023	PEACOCK TV	FOR KITCHEN TV	100-2100-600.400.000	4.99
RUDOLFO ALCARAZ	2/15/2023	SURF THRU SELMA	CAR WASH	100-2300-600.400.000	24.99
TIFFANY FLORES	1/24/2023	ZOOM	ZOOM LICENSE	100-1300-600.250.000	100.62
TIFFANY FLORES	1/24/2023	ZOOM	ZOOM LICENSE	100-1300-600.250.000	463.15
TIFFANY FLORES	1/30/2023	COSTCO	STORAGE BINS	100-1300-600.250.000	20.36
TIFFANY FLORES	2/1/2023	RITE AID	CARD - OFFICER CARRASCO FAMILY	100-1300-600.250.000	6.17
TIFFANY FLORES	2/1/2023	RODOLFO'S	HR ANALYST LUNCH	100-1300-610.920.000	45.05
TIFFANY FLORES	2/1/2023	BLOOMIE'S FLORAL	PLANT - OFFICER CARRASCO FAMILY	100-1300-600.250.000	61.78
TIFFANY FLORES	2/8/2023	ME-N-EDS PIZZERIA	ADMIN SERVICES - STAFF LUNCH	100-1600-600.250.000	104.34
TIFFANY FLORES	2/15/2023	PANADERIA VANESSA	HR MANAGER PANEL REFRESHMENTS	100-1600-600.250.000	16.00
TIFFANY FLORES	2/17/2023	FTD TOUCH OF ROSES	PLANT - K. MOSS	100-1600-600.250.000	108.48
TIFFANY FLORES	2/17/2023	CALEEB, INC	PLANT - J. CRANE	100-1600-600.250.000	92.08
TIM CANNON	2/15/2023	76 GAS STATION	FUEL FOR NEW UNIT	701-9200-600.257.000	35.01

\$ 81,881.44